



erahp.eu

Heat Pumps ERA^{pro} DATASHEET

Outdoor & indoor units

version: **ERApró-ENG-2026/02-1**

Outdoor Units

Basic Parameters	3-5
Dimensions	6
Electrical connection	7
Safety Clearances for R290 HP	8-12
Minimum Distances	13
Foundation Structure	14-15
Drainage connectiuons limitations	15
Ground Bracket	16
Coastal areas instalation	17
Performance Data	18-21
Hydraulic Characteristics	22
Accoustic Pressure	23

Indoor Units

Basic Parameters	24
CU 1 – Control Unit 1	25-27
CU 1 – Dimensions	25
CU 1 – Hydraulic scheme	26
CU 1 – Wiring Diagram	27
HU 9 – Hydraulic Unit 9	28-30
HU 9 – Dimensions	28
HU 9 – Hydraulic scheme	29
HU 9 – Wiring Diagram	30
DHWU 9 – Domestic Hot Water Unit 9	31-33
DHWU 9 – Dimensions	31
DHWU 9 – Hydraulic scheme	32
DHWU 9 – Wiring Diagram	33
Water Quality in heating systems	34

	ERA ^{pro} 6 kW 230 V	ERA ^{pro} 9 kW 230 V	ERA ^{pro} 9 kW 400 V	ERA ^{pro} 13 kW 230 V	ERA ^{pro} 13 kW 400 V	ERA ^{pro} 16 kW 400 V
Energy efficiency class (ERP at 35/55 °C)	A+++/A++					
Heating capacity range (according to A7/W35)	2.00 ~ 6.03 kW	3.50 ~ 9.04 kW		4.20 ~ 13.04 kW		6.0 ~ 16.44 kW
SCOP EN 14825, average climate (35°C/55°C)	5,13 / 3,70	5,11 / 3,77		5,18 / 3,82		5,10 / 3,80
Seasonal heating efficiency 35°C/55°C, average climate	202,3 / 145,2	201,4 / 147,9		204,4 / 149,8		201,1 / 149,2
Prated EN 14825 (35°C)	4,79 kW	7,03 kW		9,91 kW		12,35 kW
Cooling capacity range (according to A35/W7)	1,47 ~ 4,91 kW	2,33 ~ 6,96 kW		3,27 ~ 9,13 kW		4,32 ~ 11,8 kW
Sound power according to EN 12102	47 dB(A)	53 dB(A)		54 dB(A)		
Sound pressure 1m according to EN 12102	36 dB(A)	42 dB(A)		43 dB(A)		
Nominal heating water flow	1,03 m ³ /h	1,55 m ³ /h		2,2 m ³ /h		2,75 m ³ /h
Minimum heating water flow	0,72 m ³ /h	1,08 m ³ /h		1,08 m ³ /h		1,44 m ³ /h
Pressure drop of the condenser		20 kPa		22 kPa		35 kPa
Minimum volume of heating water	60 l	90 l		130 l		160 l
Maximum heating water outlet temperature	75 °C					
Min. ambient temperature – heating / DHW	-25 °C					
Max. ambient temperature – heating / DHW	43 °C					
Min. ambient temperature – cooling	10 °C					
Max. ambient temperature – cooling	43 °C					
Supply voltage	230 V		400 V	230 V		400 V
Circuit breaker size/type	1×16 A/C	1×20 A/C	3×10 A/C	1×32 A/C	3×10 A/C	3×13 A/C

	ERA ^{pro} 6 kW 230 V	ERA ^{pro} 9 kW 230 V	ERA ^{pro} 9 kW 400 V	ERA ^{pro} 13 kW 230 V	ERA ^{pro} 13 kW 400 V	ERA ^{pro} 16 kW 400 V
Running current	5 A					
Sustained current	10,6 A	15,0 A	6,0 A	21,3 A	8,3 A	10,1 A
Max. operating current	13,8 A	19,8 A	6,6 A	29,7 A	9,9 A	11,5 A
Max. el. power input (compressor)	2,7 kW	3,9 kW		5,8 kW		6,8 kW
Height without packing	1120 mm					
Width without packing	1102 mm			1377 mm		
Depth without packing	557 mm					
Weight without packing	130 kg	135 kg		190 kg		195 kg
Height with packing	1182 mm					
Width with packing	1215 mm			1490 mm		
Depth with packing	580 mm					
Dimensions of hydraulic connection	1 ¼"					
Type of refrigerant	R290					
GWP of refrigerant (IPCC AR4)	3					
Weight of refrigerant	0,75 kg	0,9 kg		1,05 kg		1,28 kg
CO₂ equivalent (IPCC AR4)	2,25 kg	2,70 kg		3,15 kg		3,84 kg
Min. distance from left side	600 mm					
Min. distance from right side	600 mm					
Min. distance from front side	1000 mm					
Min. distance from rear side	300 mm					
Min. distance from top side	1000 mm					

ERA^{pro} 6 kW

HC [kW] COP [-]

A-7/W35 2,29 – 5,69 4,04 – 3,03

A2/W35 2,69 – 5,97 4,92 – 3,96

A7/W35 2,84 – 6,3 5,86 – 4,72

A-7/W55 2,22 – 5,52 2,84 – 2,13

A2/W55 2,55 – 5,67 3,15 – 2,54

A7/W55 2,65 – 5,89 3,81 – 2,92

ERA^{pro} 9 kW

HC [kW] COP [-]

A-7/W35 3,26 – 8,1 3,96 – 2,97

A2/W35 3,82 – 8,48 4,79 – 3,86

A7/W35 4,04 – 8,99 5,82 – 4,57

A-7/W55 3,16 – 7,85 2,91 – 2,19

A2/W55 3,7 – 8,22 3,31 – 2,67

A7/W55 3,89 – 8,65 3,86 – 2,98

ERA^{pro} 13 kW

HC [kW] COP [-]

A-7/W35 4,63 – 11,75 3,94 – 2,94

A2/W35 5,42 – 12,76 4,82 – 3,87

A7/W35 5,51 – 13,15 5,72 – 4,68

A-7/W55 4,4 – 11,17 2,93 – 2,19

A2/W55 5,08 – 11,96 3,32 – 2,62

A7/W55 5,16 – 12,33 3,82 – 3,11

ERA^{pro} 16 kW

HC [kW] COP [-]

A-7/W35 5,53 – 14,03 3,86 – 2,88

A2/W35 6,48 – 15,28 4,71 – 3,78

A7/W35 6,86 – 16,37 5,6 – 4,58

A-7/W55 5,15 – 13,07 2,86 – 2,14

A2/W55 6,06 – 14,27 3,25 – 2,57

A7/W55 6,43 – 15,36 3,74 – 3,04

HC - Heating Capacity

COP - Coefficient of performance

A.../W... - Ambient temperature / Outlet Water Temperature (°C)

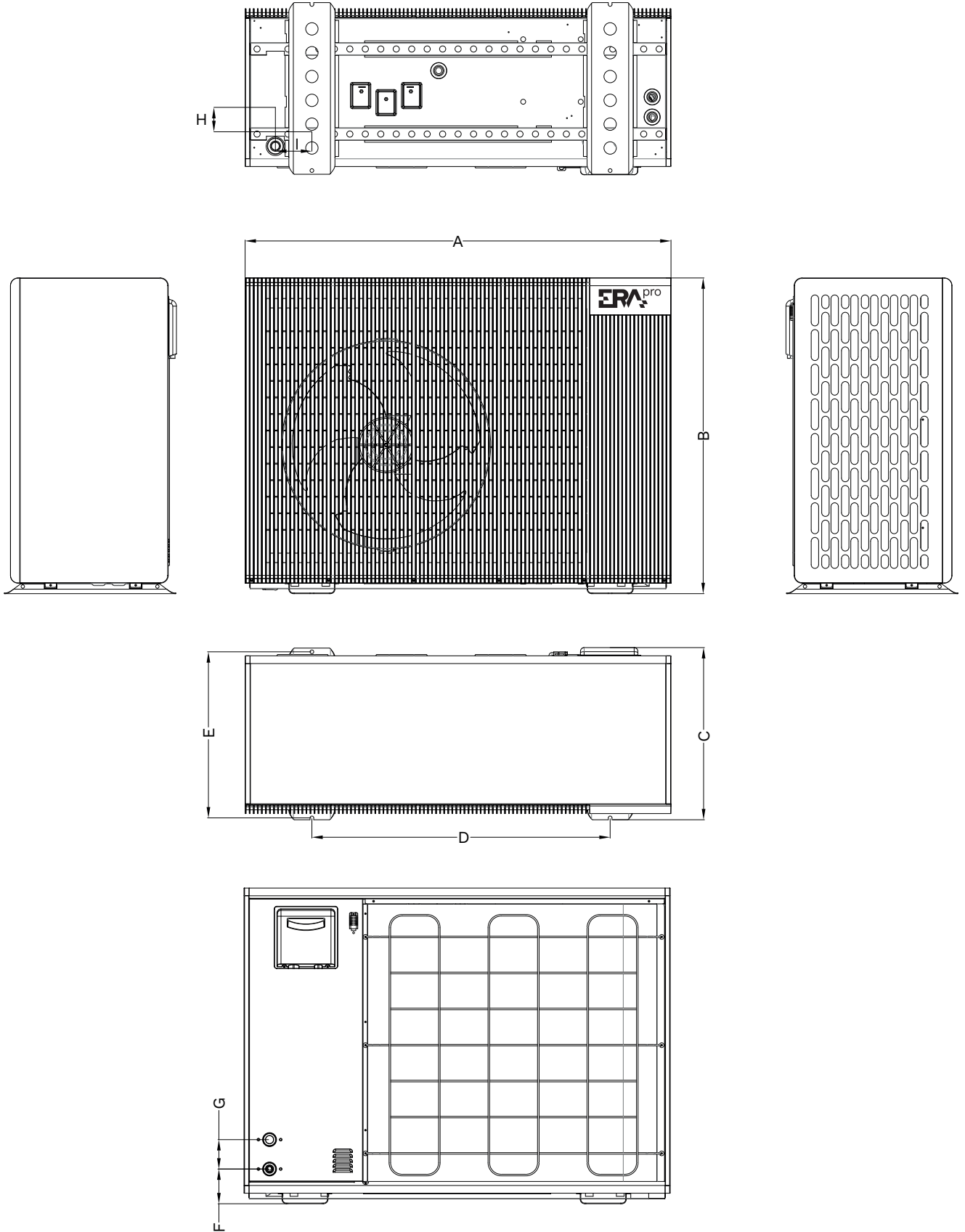

	A	B	C	D	E	F	G	H	I
6/9 kW	1102 mm	1021 mm	557 mm	706 mm	537 mm	112 mm	95 mm	79 mm	118 mm
13/16 kW	1377 mm	1021 mm	557 mm	964 mm	537 mm	112 mm	95 mm	79 mm	118 mm

ERA^{pro}
outdoor unit 6 kW / 9 kW

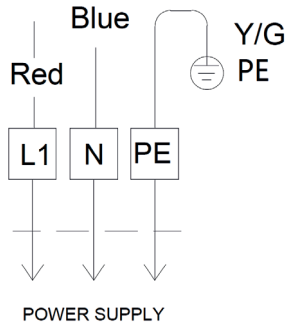

ERA^{pro}
outdoor unit 13 kW / 16 kW

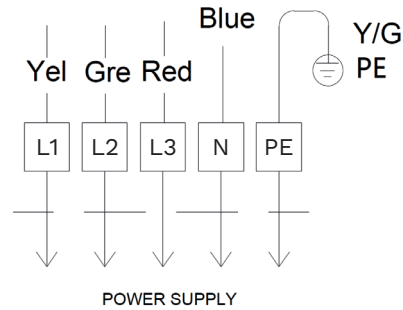

	ERA ^{pro} 6 kW	ERA ^{pro} 9 kW	ERA ^{pro} 9 kW	ERA ^{pro} 13 kW	ERA ^{pro} 16 kW
Supply voltage	230 V	230 V	400 V	400 V	400 V
Circuit breaker size/type	1x16 A/C	1x20 A/C	3x10 A/C	3x10 A/C	3x13 A/C
Sustained current	10,6 A	15,0 A	6,0 A	8,3 A	10,1 A
Max. operating current	13,8 A	19,8 A	6,6 A	9,9 A	11,5 A
Max. el. power input of compressor	2,7 kW	3,9 kW	3,9 kW	5,8 kW	6,8 kW

Circuit Breaker Conditions for ERA^{pro} 9 kW 230V

Boundary conditions of extremes	LWT	DB	Power Input	Current	Circuit Breaker	Restrictions
ERA ^{pro} 9 kW - 230 V	55	-10	3,86	19,74	1x20 A/C	No
Boundary conditions with performance limitations	LWT	DB	Power Input	Current	Circuit Breaker	Restrictions
ERA ^{pro} 9 kW - 230 V var. A	45	-10	3,29	15,89	1x16 A/C	Either without hot water or with an outlet temperature of max. 45 °C. (cosfi=0,9)
ERA ^{pro} 9 kW - 230 V var. B	40	-10	3,11	15,04	1x16 A/C	Either without hot water or with an outlet temperature of max. 40 °C. (cosfi=0,85)

LWT - Water outlet temperature (°C)

DB - Drybulb temperature of air (°C)

**SAFE INSTALLATION
VIEW**

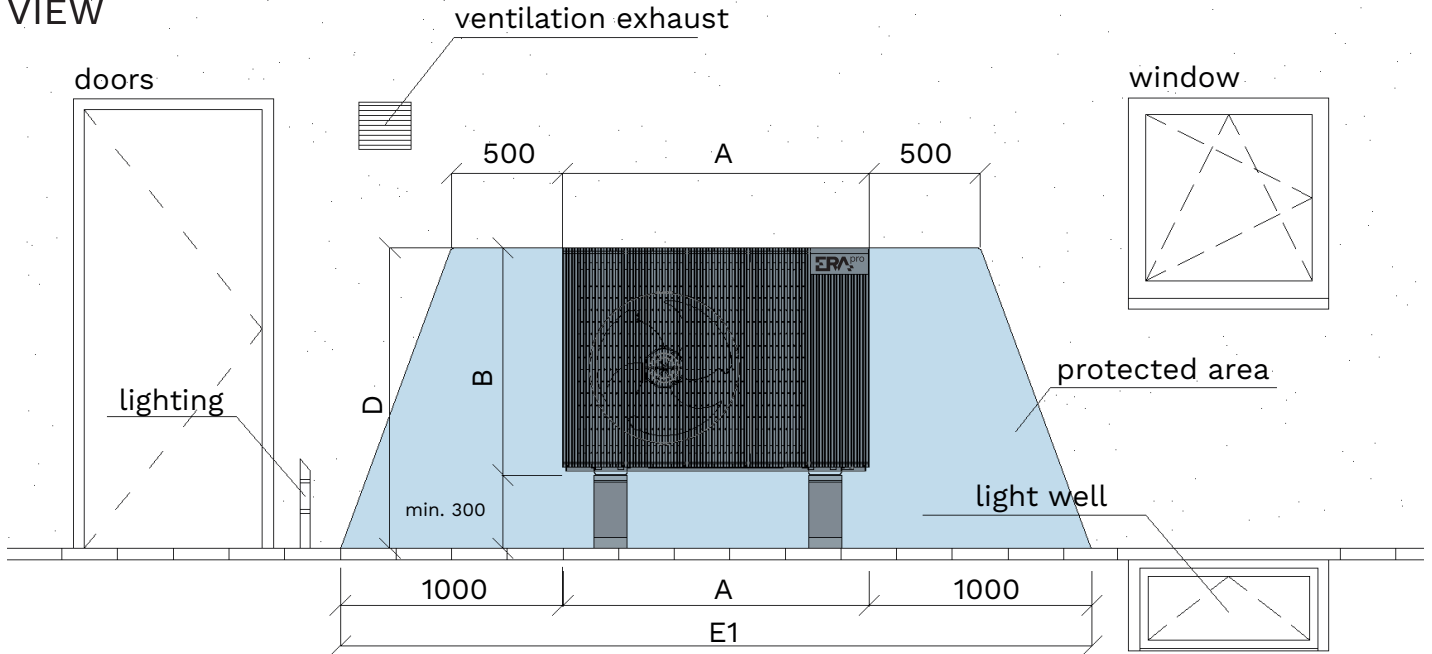

**SAFE INSTALLATION
FLOOR PLAN**

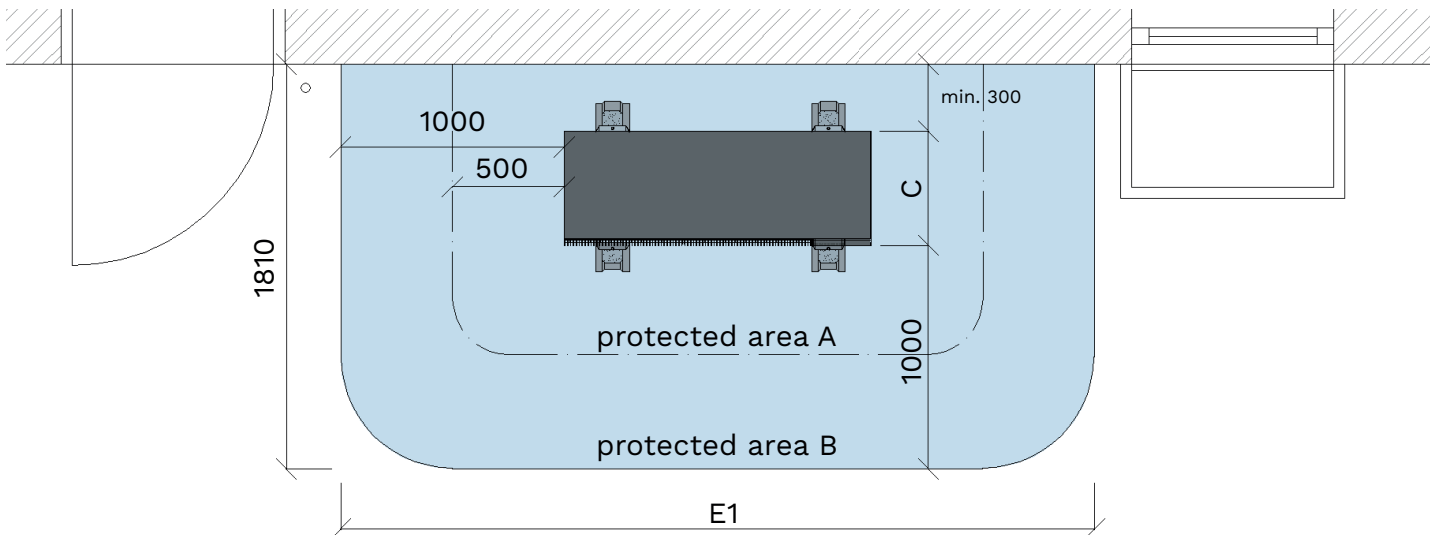

Dimension	Marker	ERA ^{pro} 6 kW	ERA ^{pro} 9 kW	ERA ^{pro} 13 kW	ERA ^{pro} 16 kW
Outdoor unit width	A	1102 mm	1102 mm	1377 mm	1377 mm
Outdoor unit height	B	1120 mm	1120 mm	1120 mm	1120 mm
Outdoor unit depth	C	557 mm	557 mm	557 mm	557 mm
Minimum height of the upper edge from the ground	D	1420 mm	1420 mm	1420 mm	1420 mm
Basic width of protected area B	E1	3102 mm	3102 mm	3377 mm	3377 mm

**RISK INSTALLATION
VIEW**

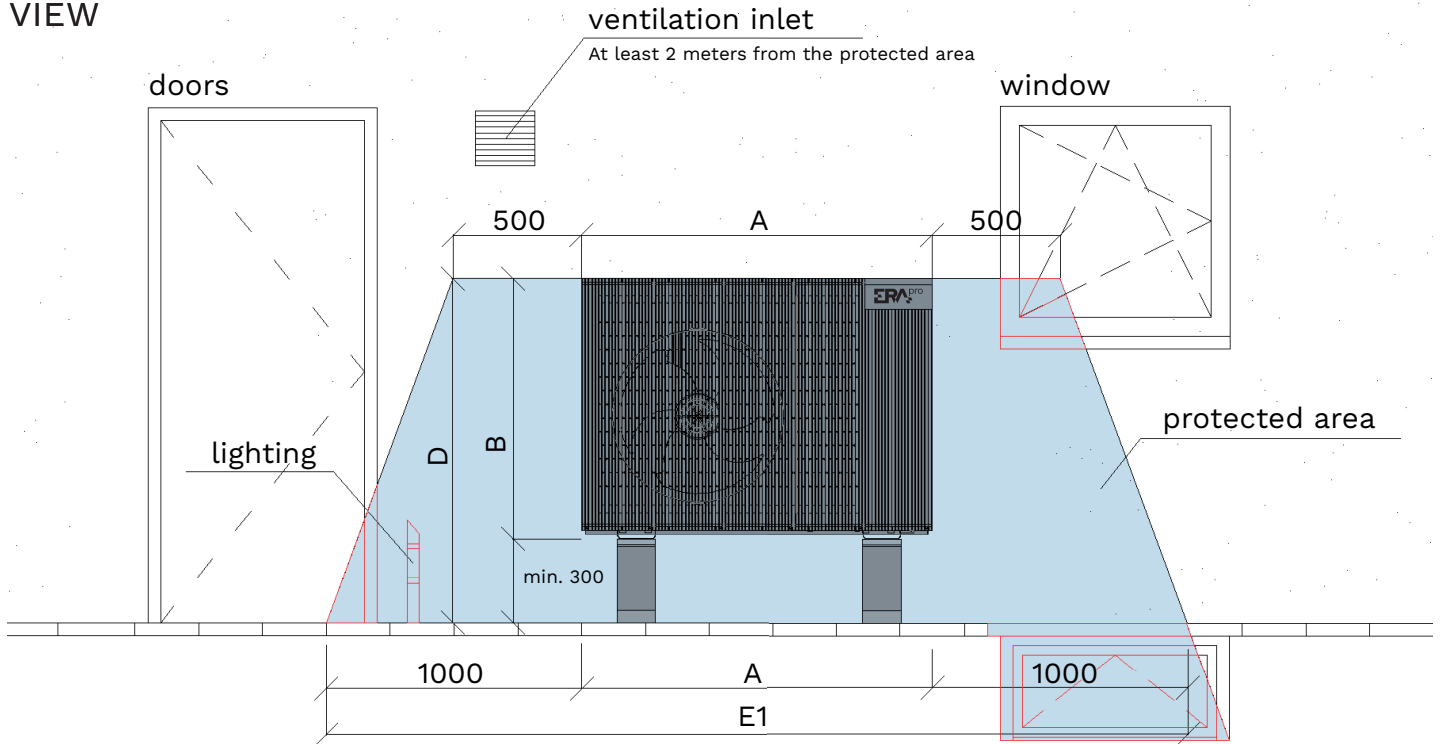

**RISK INSTALLATION
FLOOR PLAN**

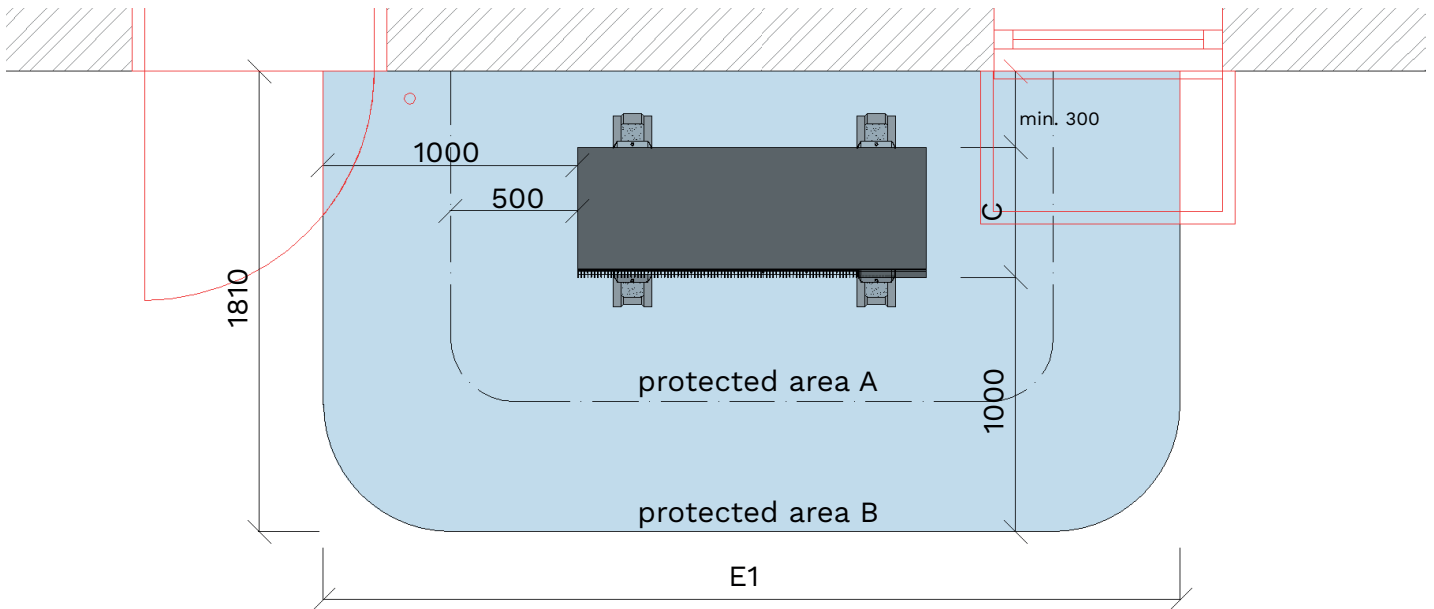

Protected areas

Area A	Prohibition of placing sources of flame, combustion, and sparks; working with electrical equipment without ATEX certification; all penetrations into the building or connections to the sewage system; ventilation openings; lighting.
Area B	Prohibition of placing open flame sources, roof drains, ventilation intakes, ventilation exhausts, door and window openings, building penetrations, lighting.
Area C	Prohibition of placing open flame sources, roof drains without siphons and ventilation, ventilation intake. Limited distances from windows, doors, skylights, and similar openings.

**INSTALLATION ON THE FACADE
UNDER THE WINDOW**

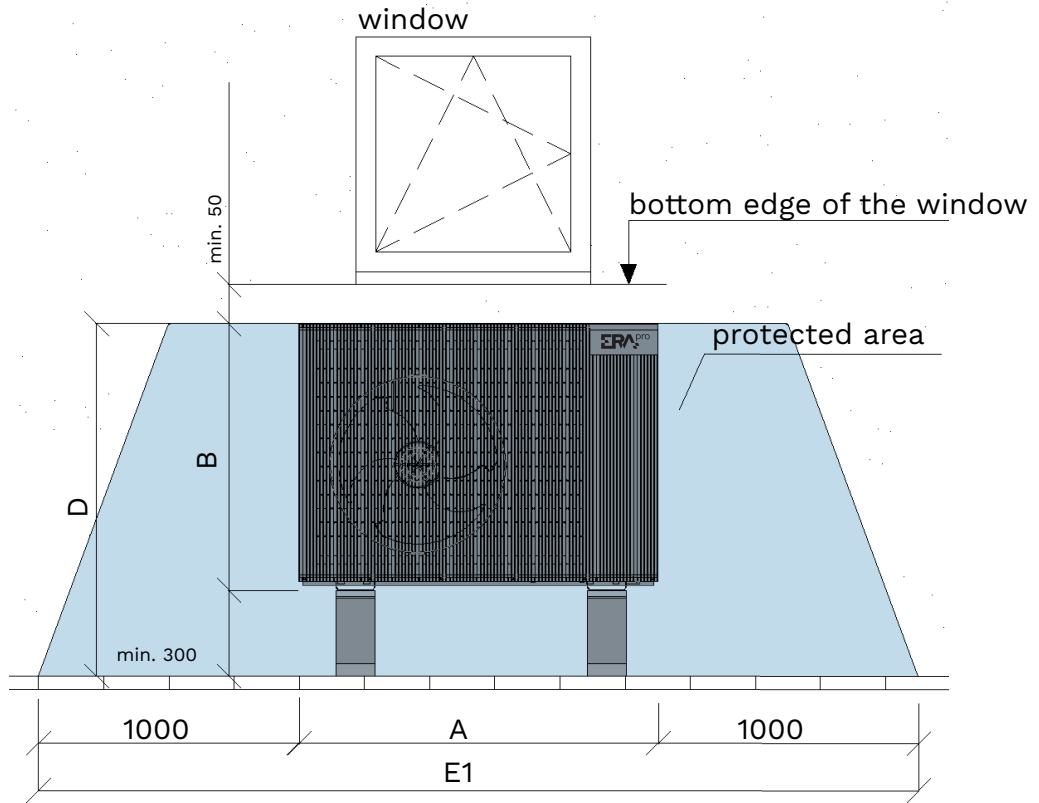

**PERMITTED REDUCTION
OF THE PROTECTED AREA
ON ONE SIDE**

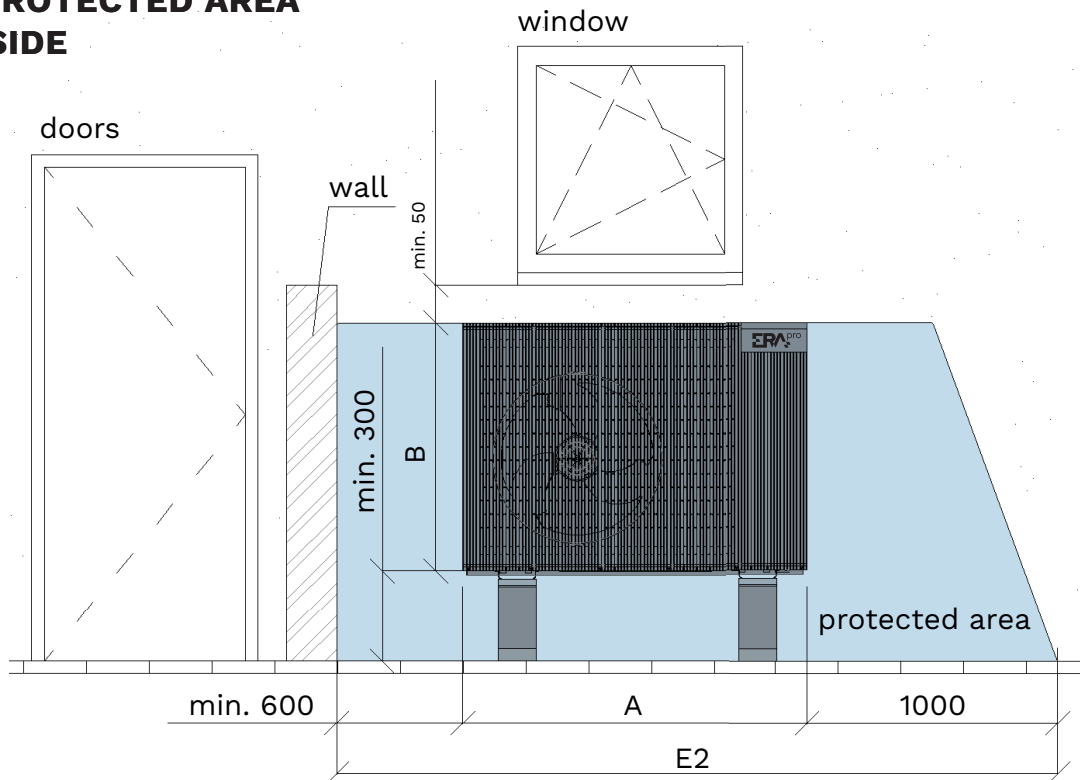

**PROTECTED AREA WHEN INSTALLING A HEAT PUMP
AT A GREATER DISTANCE FROM THE BUILDING**

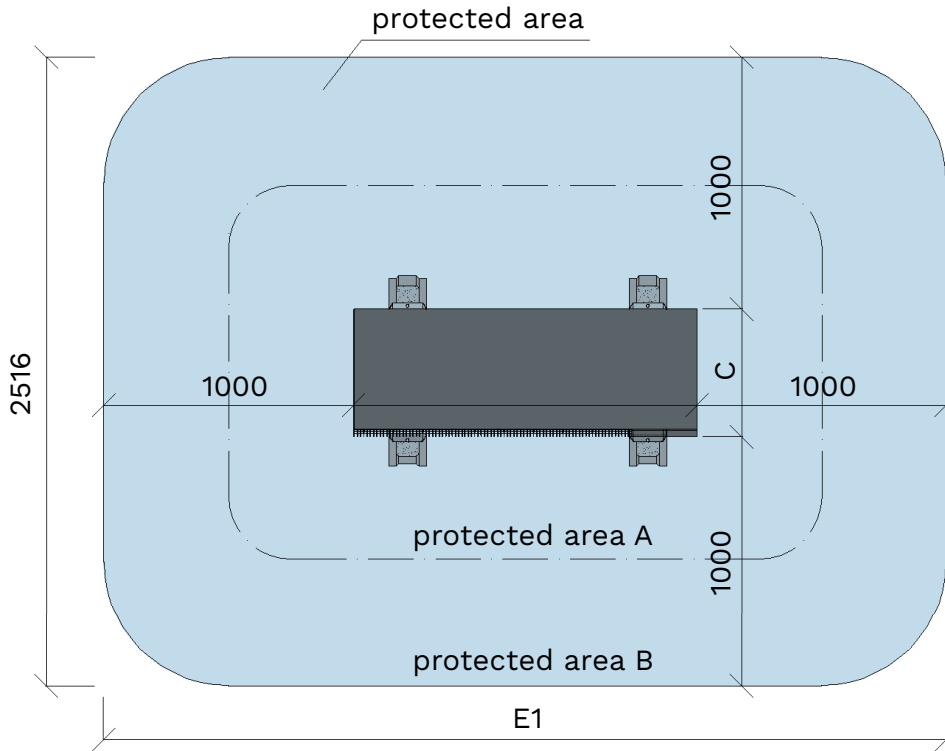

INSTALLATION ON FLAT ROOFS IN PROTECTED AREAS A/B/C

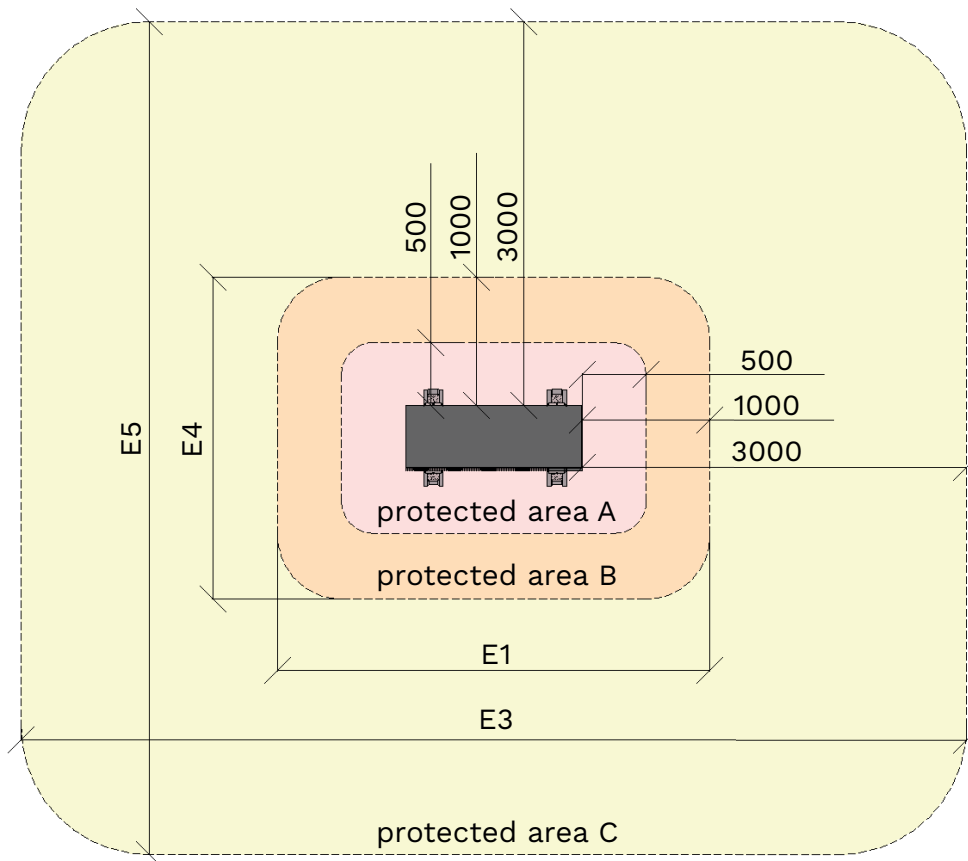

INSTALLATION ON A FLAT ROOF WITH A PARAPET WALL

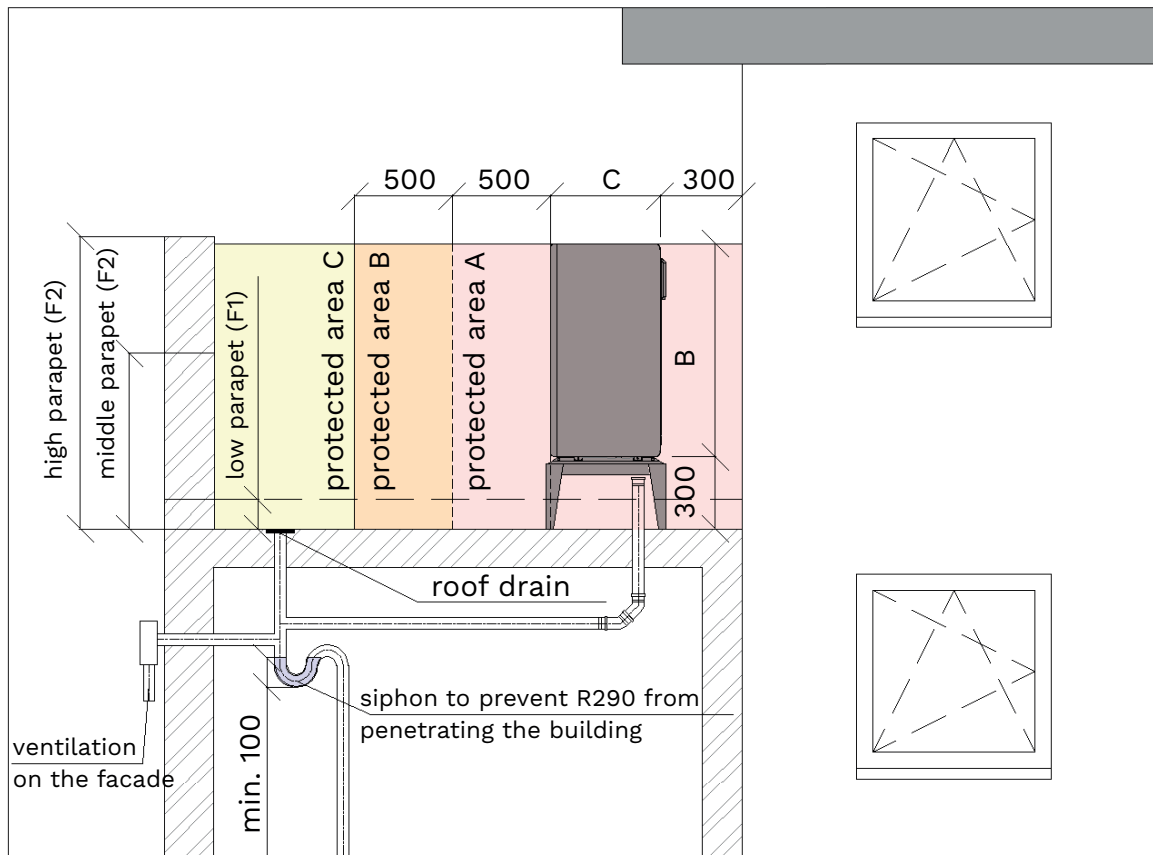

Dimension	Marker	ERA ^{pro} 6 kW	ERA ^{pro} 9 kW	ERA ^{pro} 13 kW	ERA ^{pro} 16 kW
Width of outdoor unit	A	1102 mm	1102 mm	1377 mm	1377 mm
Height of outdoor unit	B	1120 mm	1120 mm	1120 mm	1120 mm
Depth of outdoor unit	C	557 mm	557 mm	557 mm	557 mm
Minimum height of upper edge from ground level	D	1420 mm	1420 mm	1420 mm	1420 mm
Basic width of protected zone B	E1	3102 mm	3102 mm	3377 mm	3377 mm
Reduced width of protected area on one side	E2	2702 mm	2702 mm	2977 mm	2977 mm
Basic width of protected area C	E3	7102 mm	7102 mm	7377 mm	7377 mm
Basic depth of protected area B	E4	2557 mm	2557 mm	2557 mm	2557 mm
Basic depth of protected area C	E5	6557 mm	6557 mm	6557 mm	6557 mm
Height of low parapet	F1	up to 300 mm - considered an open installation			
Height of medium parapet	F2	300 to 600 mm - the parapet must be equipped with ventilation openings (at least 50% of the parapet area must be covered by ventilation openings)			
Height of high parapet	F3	over 600 mm - forced ventilation of the parapet must be added in case of R290 refrigerant leakage			

Protected areas

Area A	Prohibition of placing sources of flame, combustion, and sparks; working with electrical equipment without ATEX certification; all penetrations into the building or connections to the sewage system; ventilation openings; lighting.
Area B	Prohibition of placing open flame sources, roof drains, ventilation intakes, ventilation exhausts, door and window openings, building penetrations, lighting.
Area C	Prohibition of placing open flame sources, roof drains without siphons and ventilation, ventilation intake. Limited distances from windows, doors, skylights, and similar openings.

INSTALLATION IN CORNER

(MIN.DISTANCES FROM WALLS AND OTHER HEAT PUMPS)

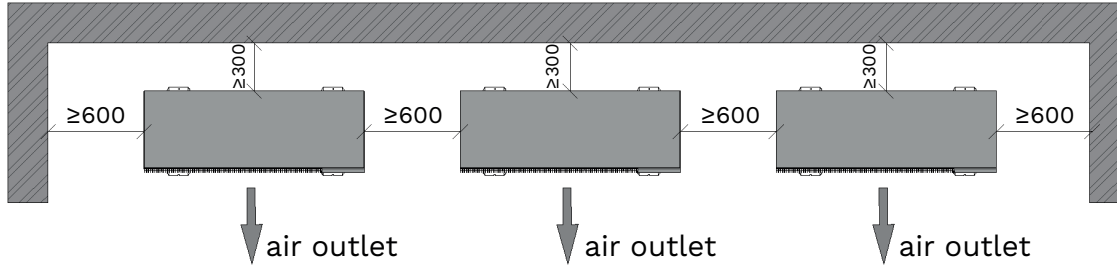

PLACEMENT OF THE UNITS BACK-TO-BACK

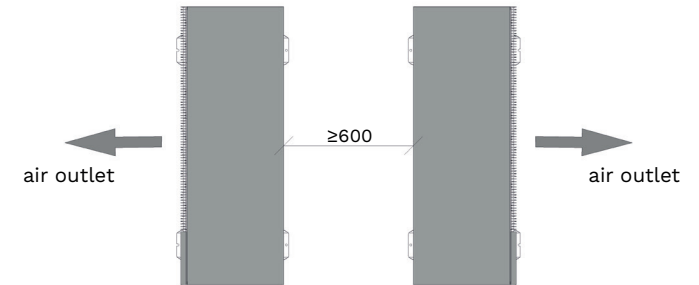

INSTALLATION OF 1 ODU UNDER BALCONY SLAB

CEILING (BALCONY SLAB)

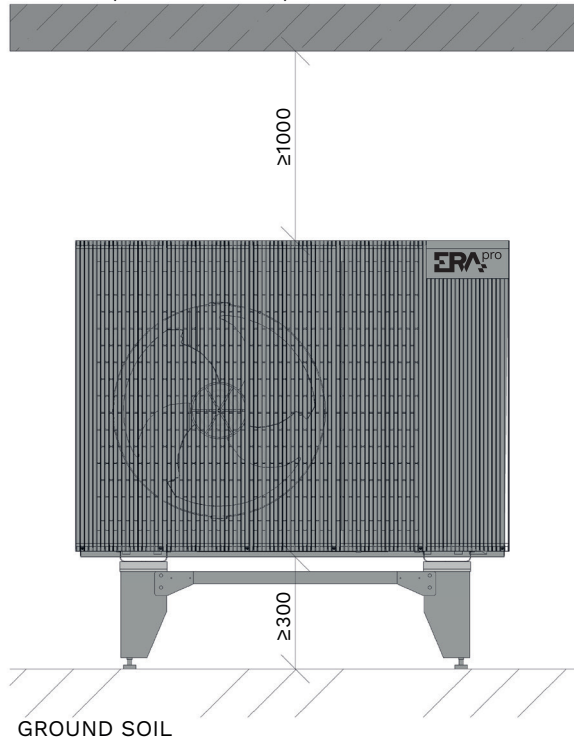

INSTALLATION OF 1 ODU BETWEEN THE WALLS

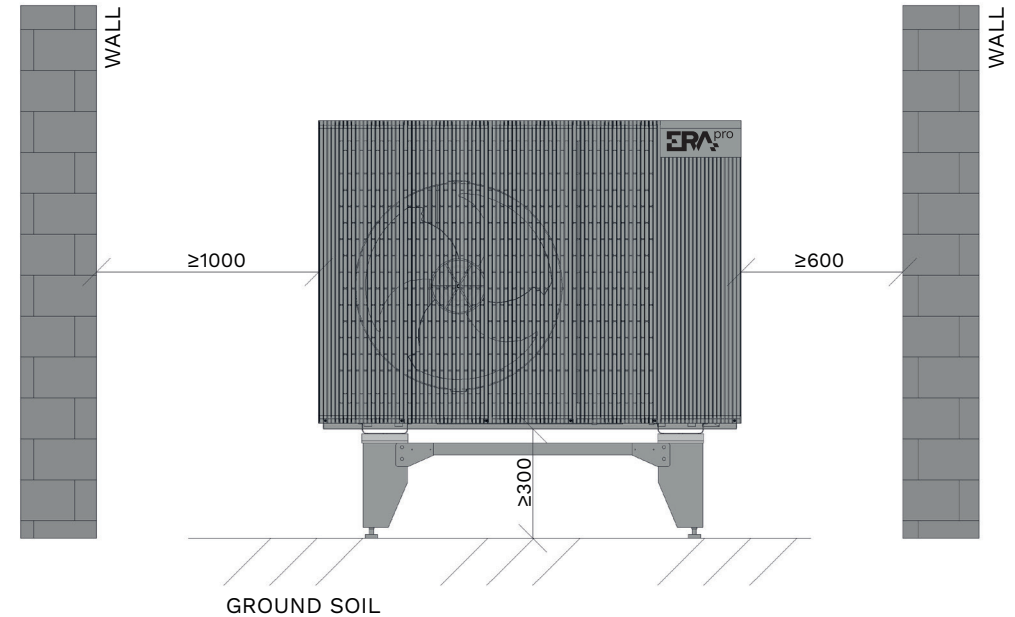

VIEW OF THE FOUNDATION STRUCTURE

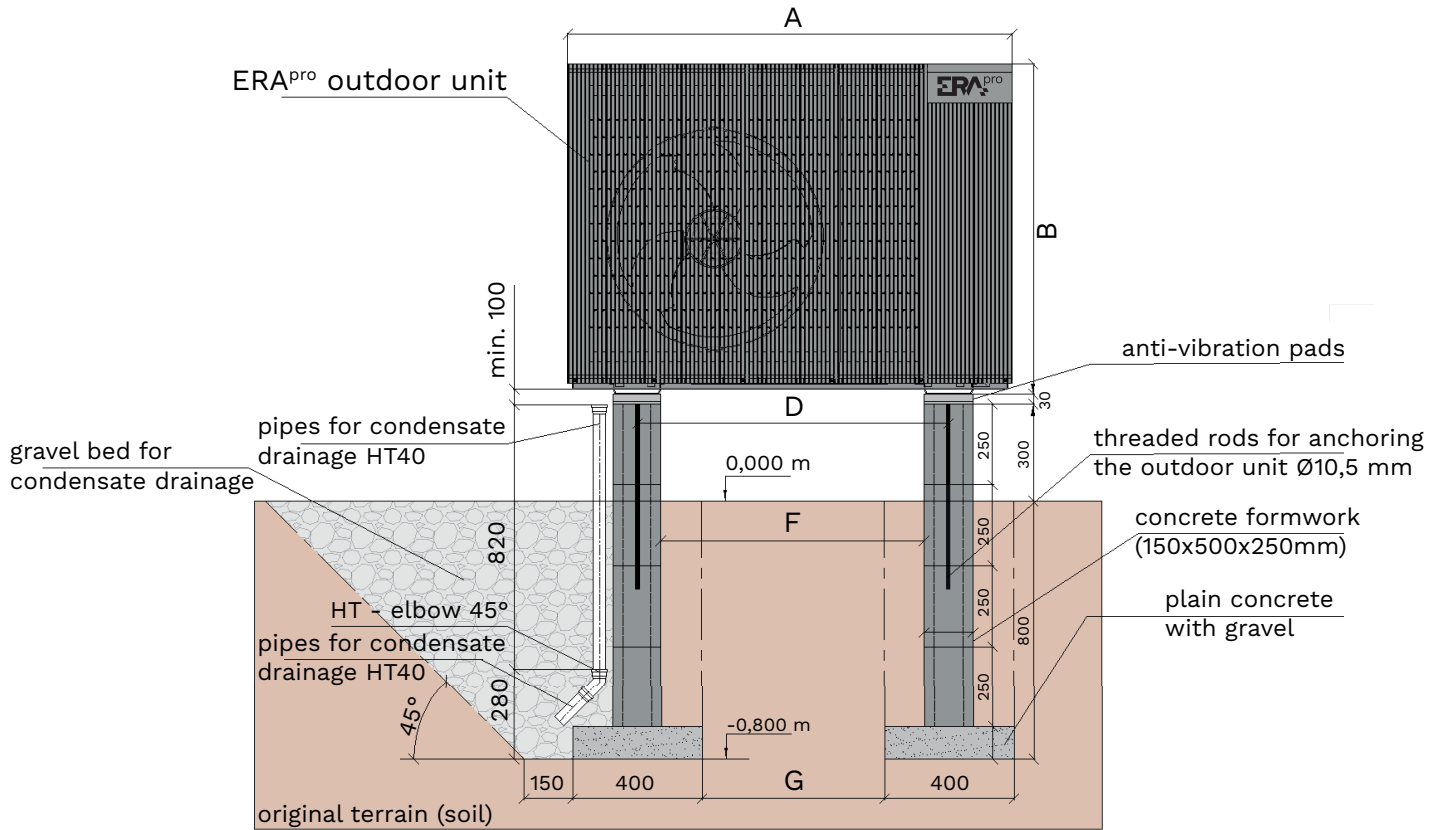

PLAN OF THE FOUNDATION STRUCTURE

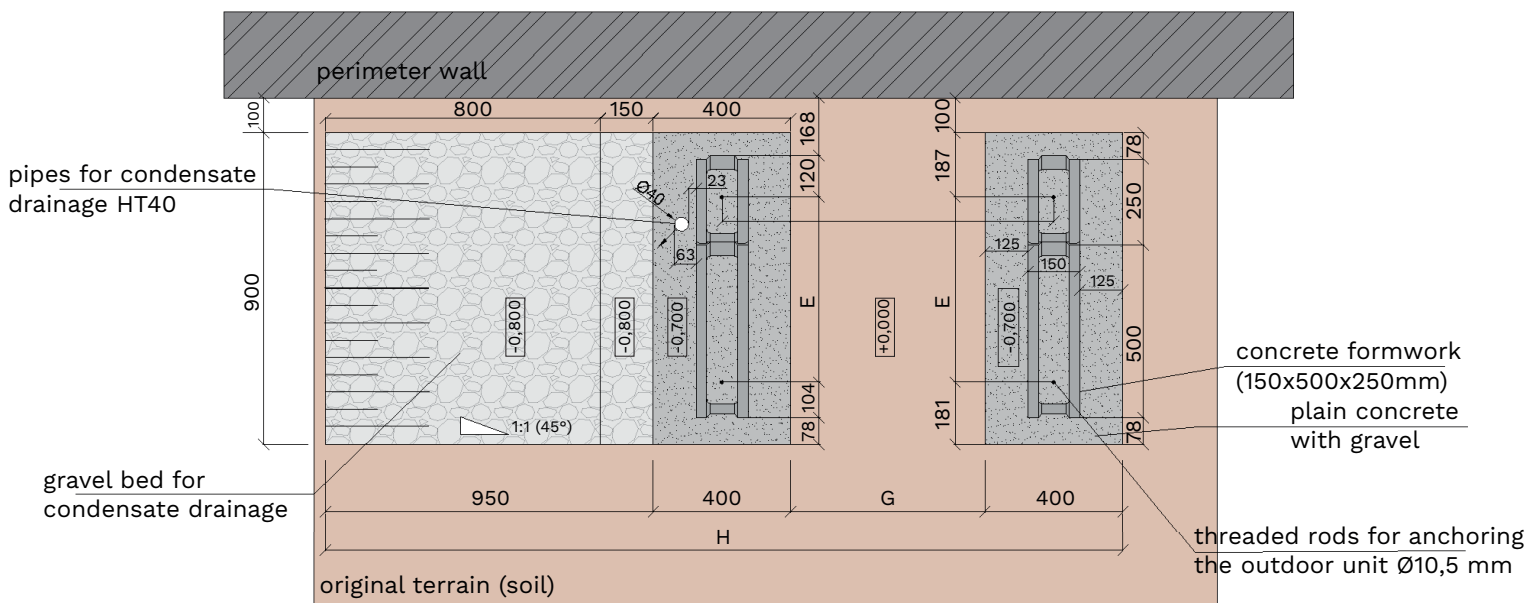

PLAN OF OUTDOOR UNIT INSTALLATION

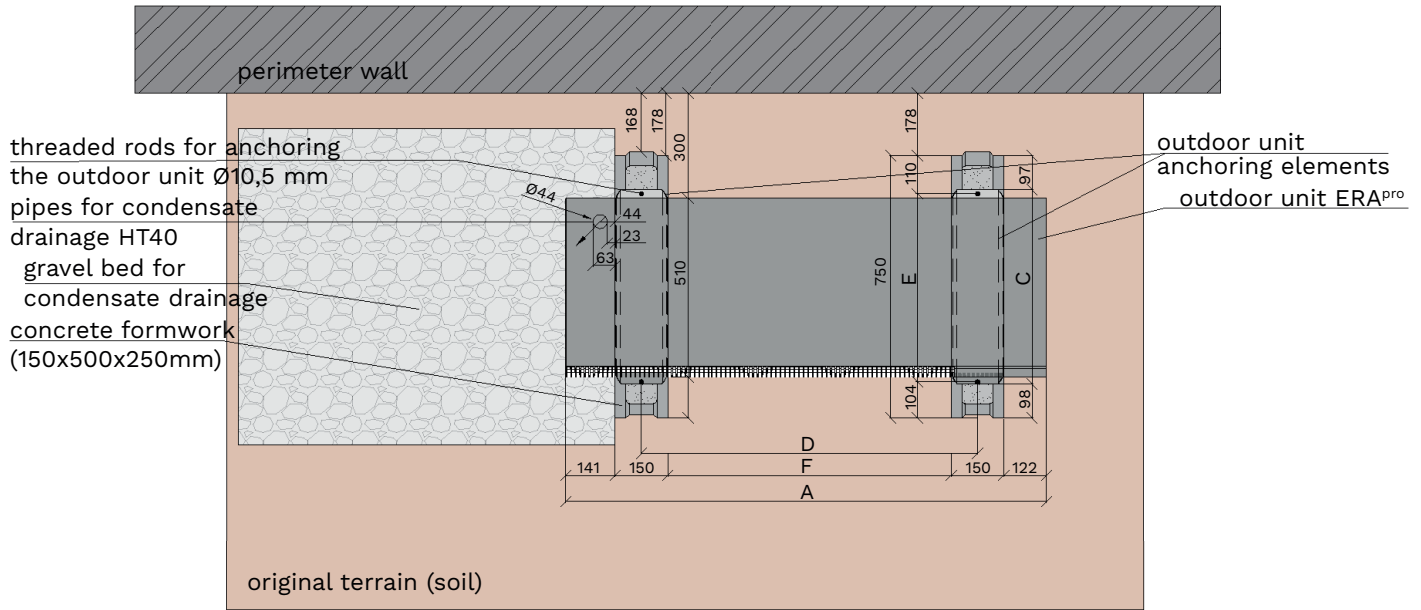

DRAINAGE CONNECTIONS LIMITATIONS

Immerse in gravel bed
RECOMMENDED for proper condensate drainage during defrost.

Connection to sewerage or drainage is only possible with a frost-proof siphon and regular checking of the water level in the siphon.
NOT RECOMMENDED.

Direct connection to the sewer system or drainage is **PROHIBITED.**

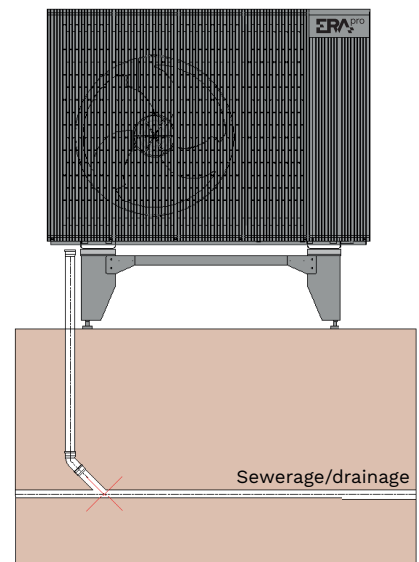
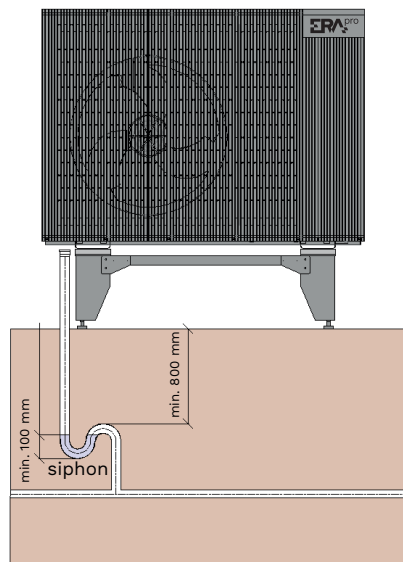
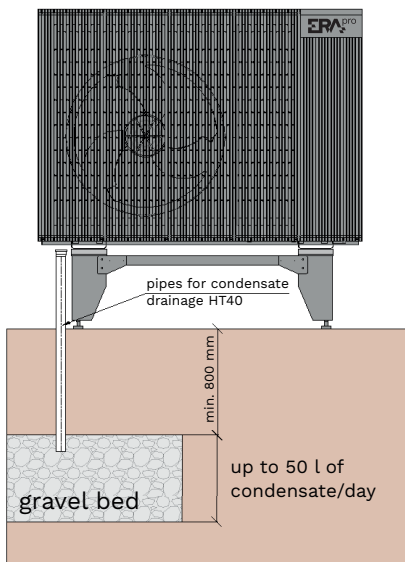

Dimension	Marker	ERA ^{pro} 6 kW	ERA ^{pro} 9 kW	ERA ^{pro} 13 kW	ERA ^{pro} 16 kW
Width of outdoor unit	A	1102 mm	1102 mm	1377 mm	1377 mm
Height of outdoor unit	B	1120 mm	1120 mm	1120 mm	1120 mm
Depth of outdoor unit	C	557 mm	557 mm	557 mm	557 mm
Longitudinal axial spacing of anchoring rods	D	706 mm	706 mm	964 mm	964 mm
Transverse axial spacing of anchoring rods	E	537 mm	537 mm	537 mm	537 mm
Clear axial spacing of anchoring rods	F	557 mm	557 mm	814 mm	814 mm
Distance between foundation strips	G	308 mm	308 mm	565 mm	565 mm
Excavation pit width	H	2058 mm	2058 mm	2315 mm	2315 mm

- Secure and stable mounting of the outdoor unit.
- Minimization of vibrations and noise
- Weather-resistant
- Quick installation on a solid foundation
- Modern look in the same color as the heat pump

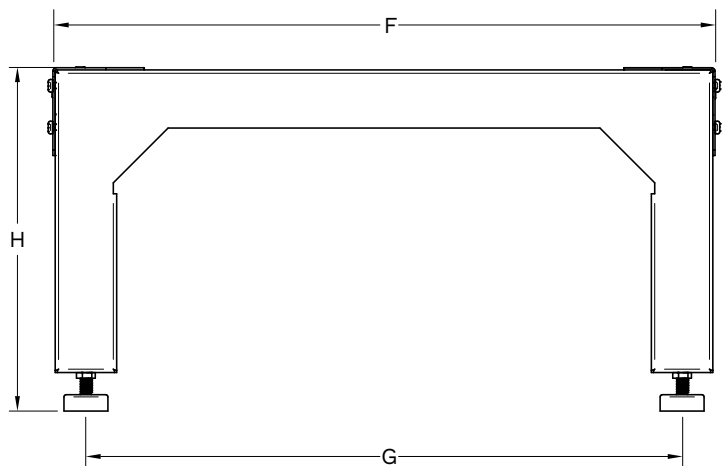
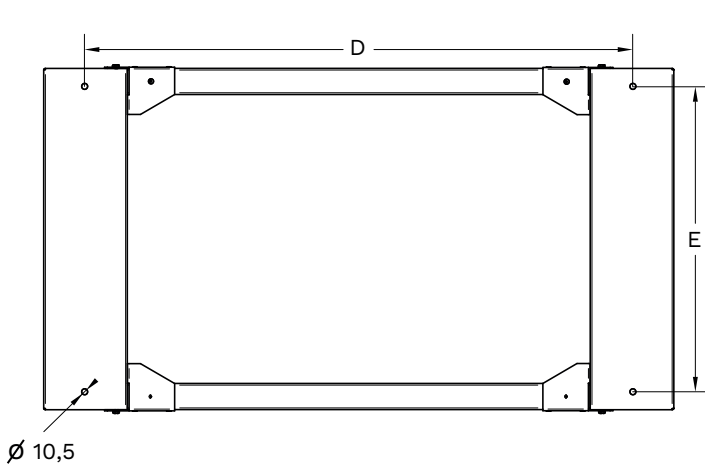
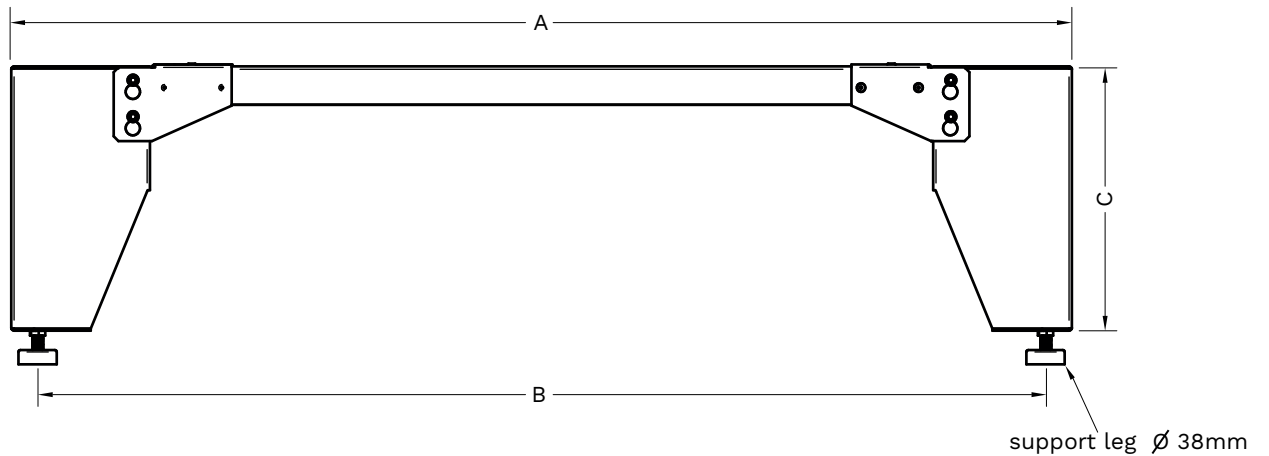

	A	B	C	D	E	F	G	H
6/9 kW	850 mm	765 mm	276 mm	706 mm	537 mm	604 mm	544 mm	min 300 mm / max 329
13/16 kW	1108 mm	1053 mm	276 mm	964 mm	537 mm	604 mm	544 mm	min 300 mm / max 329

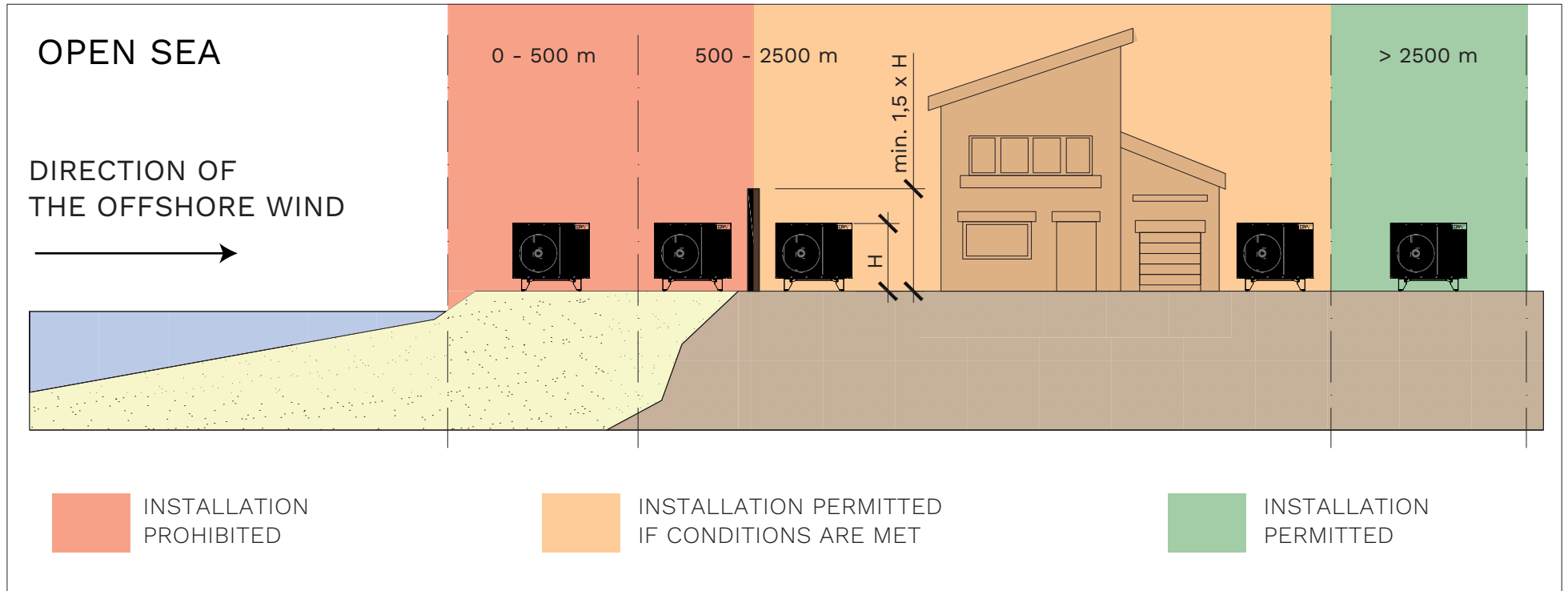

- Installation of the unit at a distance of less than 500 m from the sea coast is not permitted.
- If the unit is located within 500 to 2,500 m of the coast, it must be installed on the leeward side of the building, i.e., on the side protected from direct exposure to sea winds. In this area, it is recommended to use wind protection, preferably made of concrete or metal, which minimizes the effect of salt aerosol and thus the risk of corrosion. The protective structure must reach at least 150% of the total height of the ERApro unit, including the bracket/base.
- If installation near the coast is unavoidable, it must be taken into account that exposure to salty air can lead to a dramatic reduction in the overall service life of the equipment.

ERA^{pro} 6 kW

Ambient temperature	Power output (kW)		
	MAX	MIN	NOM
-25	3,11	1,24	3,11
-20	3,87	1,55	3,87
-15	4,55	1,82	4,55
-10	5,56	2,02	5,05
-7	5,69	2,29	5,17
-5	5,73	2,34	5,20
0	5,83	2,49	5,3
2	5,97	2,69	5,43
5	6,17	2,78	5,61
7	6,3	2,84	5,73
10	6,47	2,91	5,88
15	6,68	3	6,07
20	6,92	3,11	6,29
25	7,15	3,22	6,5
30	7,38	3,32	6,71
35	7,58	3,41	6,89
40	7,79	3,5	7,08
45	8	3,6	7,27

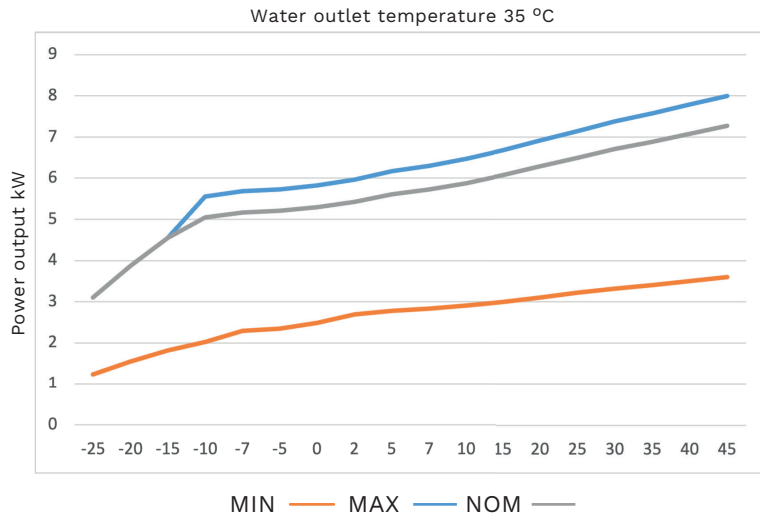

Ambient temperature °C	Power output (kW)		
	MAX	MIN	NOM
-25	2,94	1,18	2,94
-20	3,73	1,49	3,73
-15	4,41	1,76	4,41
-10	5,46	1,98	4,96
-7	5,61	2,26	5,1
-5	5,64	2,31	5,12
0	5,72	2,44	5,2
2	5,82	2,62	5,29
5	5,96	2,68	5,42
7	6,09	2,74	5,54
10	6,26	2,82	5,69
15	6,46	2,91	5,87
20	6,66	2,99	6,05
25	6,84	3,08	6,22
30	7,03	3,16	6,39
35	7,23	3,25	6,57
40	7,44	3,35	6,76
45	7,65	3,44	6,95

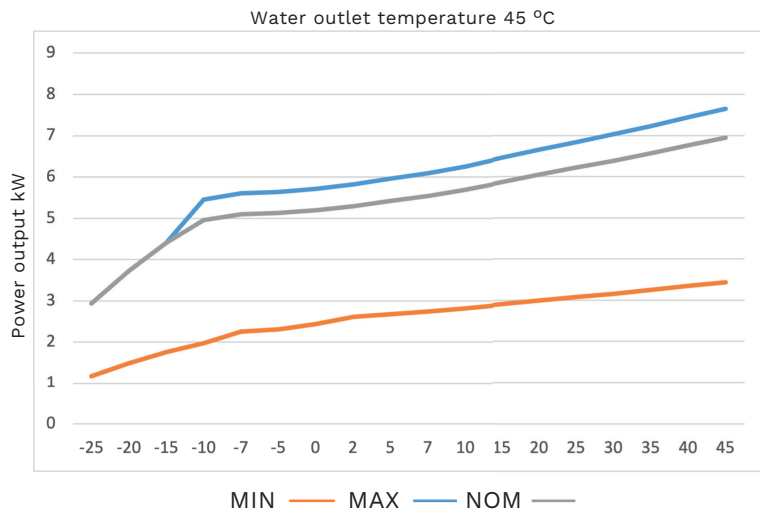

Ambient temperature	Power output (kW)		
	MAX	MIN	NOM
-25	2,34	0,94	2,34
-20	2,99	1,2	2,99
-15	3,51	1,4	3,51
-10	4,33	1,58	3,94
-7	4,7	1,89	4,27
-5	4,77	1,95	4,33
0	4,96	2,12	4,51
2	5,17	2,33	4,7
5	5,4	2,43	4,91
7	5,59	2,51	5,08
10	5,8	2,61	5,27
15	6	2,7	5,45
20	6,14	2,76	5,58
25	6,24	2,81	5,67
30	6,37	2,87	5,79
35	6,51	2,93	5,92
40	6,7	3,01	6,09
45	6,88	3,09	6,25

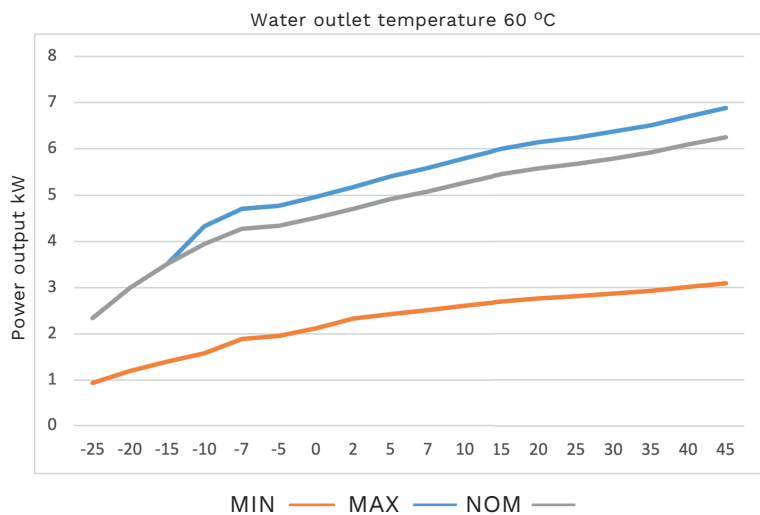

ERA^{pro} 9 kW

Ambient temperature	Power output (kW)		
	MAX	MIN	NOM
-25	4,48	1,79	4,48
-20	5,54	2,22	5,54
-15	6,49	2,6	6,49
-10	7,9	2,87	7,18
-7	8,1	3,26	7,36
-5	8,15	3,34	7,41
0	8,29	3,54	7,54
2	8,48	3,82	7,71
5	8,77	3,95	7,97
7	8,99	4,04	8,17
10	9,26	4,17	8,42
15	9,63	4,33	8,75
20	9,91	4,46	9,01
25	10,1	4,54	9,18
30	10,3	4,63	9,36
35	10,52	4,73	9,56
40	10,78	4,85	9,8
45	11,08	4,98	10,07

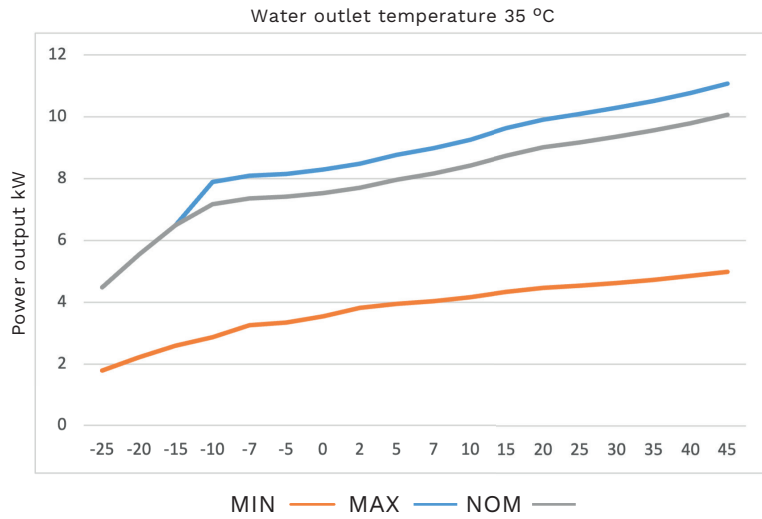

Ambient temperature °C	Power output (kW)		
	MAX	MIN	NOM
-25	4,25	1,7	4,25
-20	5,35	2,14	5,35
-15	6,3	2,52	6,3
-10	7,78	2,83	7,07
-7	7,98	3,21	7,25
-5	8,03	3,28	7,29
0	8,16	3,48	7,42
2	8,35	3,76	7,59
5	8,62	3,88	7,84
7	8,81	3,96	8,01
10	9,11	4,1	8,28
15	9,39	4,23	8,54
20	9,63	4,33	8,75
25	9,82	4,42	8,93
30	9,99	4,49	9,08
35	10,15	4,57	9,23
40	10,37	4,67	9,43
45	10,6	4,77	9,64

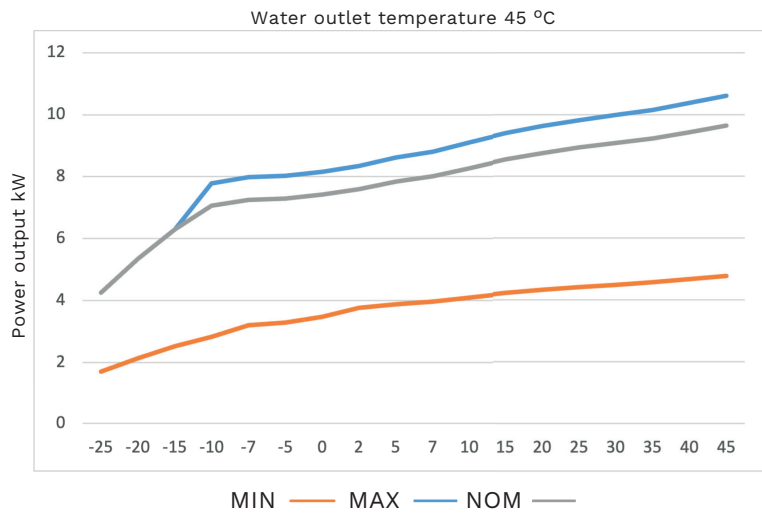

Ambient temperature	Power output (kW)		
	MAX	MIN	NOM
-25	3,43	1,37	3,43
-20	4,07	1,63	4,07
-15	4,77	1,91	4,77
-10	5,95	2,16	5,41
-7	6,56	2,64	5,96
-5	6,69	2,74	6,08
0	7,02	2,99	6,38
2	7,37	3,32	6,7
5	7,7	3,47	7
7	7,95	3,58	7,23
10	8,24	3,71	7,49
15	8,42	3,79	7,65
20	8,62	3,88	7,84
25	8,77	3,95	7,97
30	8,88	3,99	8,07
35	9,04	4,07	8,22
40	9,24	4,16	8,4
45	9,45	4,25	8,59

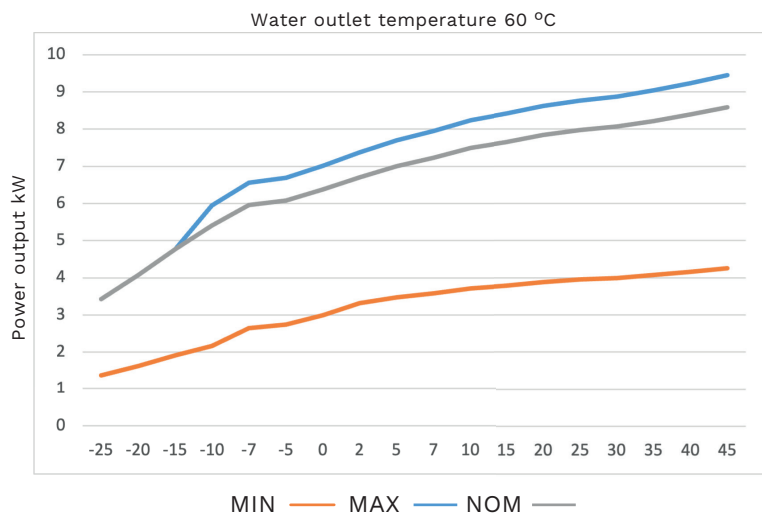

ERA^{pro} 13 kW

Ambient temperature	Power output (kW)		
	MAX	MIN	NOM
-25	6,39	2,55	6,39
-20	7,87	3,15	7,87
-15	9,06	3,62	9,06
-10	10,85	4,1	10,24
-7	11,75	4,63	10,44
-5	11,98	4,77	10,57
0	12,58	5,12	10,9
2	12,76	5,42	10,94
5	12,91	5,48	11,07
7	13,15	5,51	11,13
10	13,38	5,61	11,33
15	13,97	5,85	11,82
20	14,73	6,07	12,27
25	15,69	6,35	12,83
30	16,87	6,68	13,5
35	17,42	6,9	13,94
40	17,85	7,07	14,28
45	18,32	7,25	14,65

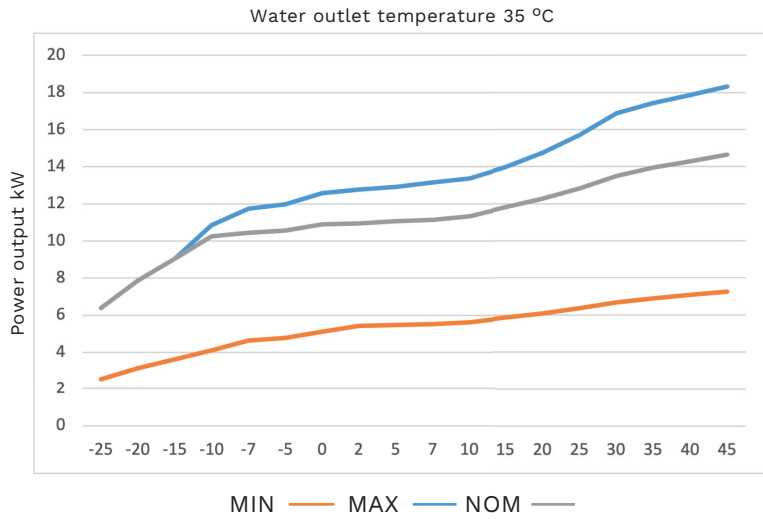

Ambient temperature °C	Power output (kW)		
	MAX	MIN	NOM
-25	6,02	2,41	6,02
-20	7,47	2,99	7,47
-15	8,76	3,5	8,76
-10	10,7	4,04	10,11
-7	11,41	4,49	10,14
-5	11,55	4,59	10,19
0	11,92	4,85	10,33
2	12,15	5,15	10,41
5	12,28	5,21	10,52
7	12,51	5,24	10,59
10	12,73	5,33	10,77
15	13,3	5,57	11,25
20	14,02	5,78	11,68
25	14,92	6,04	12,21
30	16,06	6,36	12,84
35	16,58	6,56	13,26
40	16,98	6,72	13,58
45	17,42	6,9	13,94

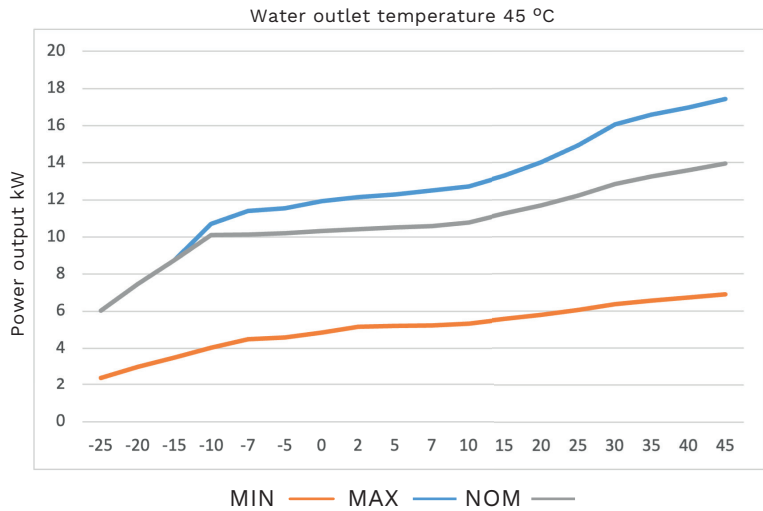

Ambient temperature	Power output (kW)		
	MAX	MIN	NOM
-25	5,26	2,1	5,26
-20	6,64	2,65	6,64
-15	7,99	3,19	7,99
-10	9,44	3,61	9,03
-7	10,24	4,03	9,1
-5	10,4	4,13	9,17
0	10,8	4,39	9,36
2	11,11	4,72	9,53
5	11,21	4,76	9,61
7	11,43	4,79	9,67
10	11,63	4,87	9,84
15	12,14	5,09	10,28
20	12,79	5,28	10,66
25	13,63	5,52	11,15
30	14,66	5,81	11,73
35	15,13	5,99	12,11
40	15,51	6,14	12,41
45	15,91	6,3	12,73

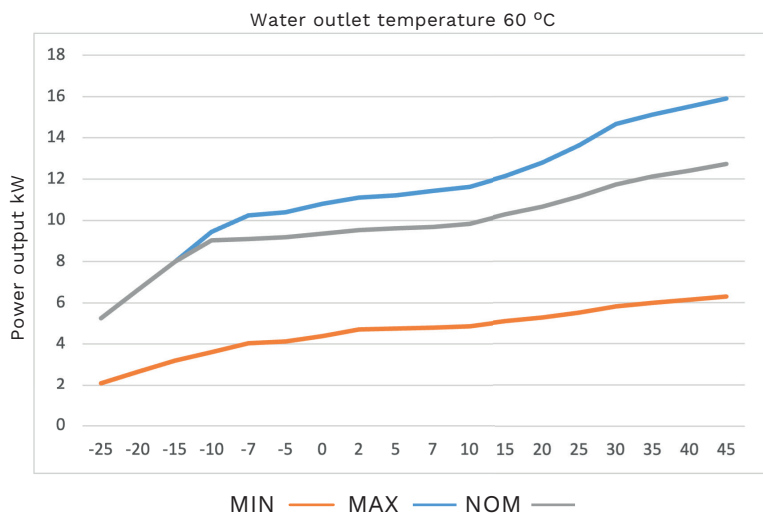

ERA^{pro} 16 kW

Ambient temperature	Power output (kW)		
	MAX	MIN	NOM
-25	7,42	2,97	7,42
-20	9,53	3,81	9,53
-15	10,6	4,24	10,6
-10	13,55	5,12	12,8
-7	14,03	5,53	12,47
-5	14,27	5,68	12,59
0	14,9	6,06	12,91
2	15,28	6,48	13,09
5	15,81	6,71	13,55
7	16,37	6,86	13,85
10	16,4	6,87	13,87
15	16,67	6,98	14,11
20	17,06	7,04	14,21
25	17,59	7,12	14,39
30	18,29	7,24	14,63
35	18,19	7,2	14,55
40	18,25	7,23	14,6
45	18,39	7,28	14,71

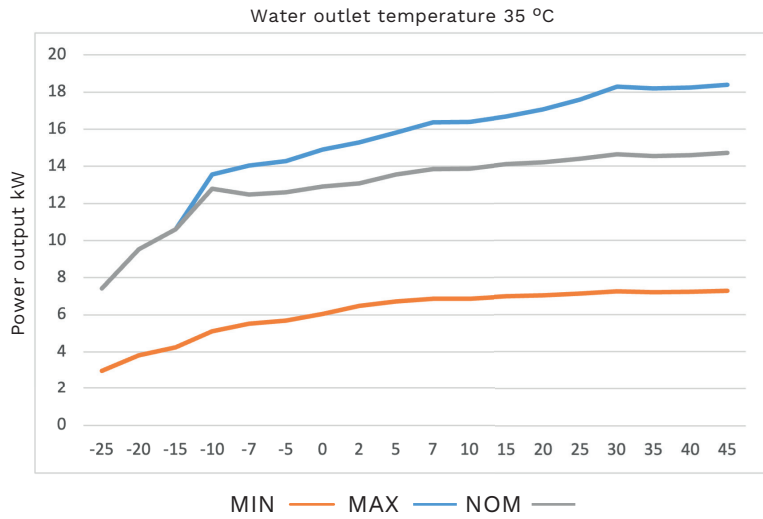

Ambient temperature °C	Power output (kW)		
	MAX	MIN	NOM
-25	6,88	2,75	6,88
-20	8,94	3,58	8,94
-15	10,19	4,08	10,19
-10	12,58	4,75	11,88
-7	13,49	5,31	11,99
-5	13,73	5,45	12,11
0	14,34	5,83	12,43
2	14,71	6,24	12,61
5	15,24	6,47	13,06
7	15,8	6,62	13,37
10	15,82	6,63	13,39
15	16,1	6,74	13,62
20	16,47	6,8	13,73
25	17	6,88	13,91
30	17,69	7	14,15
35	17,58	6,96	14,06
40	17,64	6,99	14,11
45	17,78	7,04	14,22

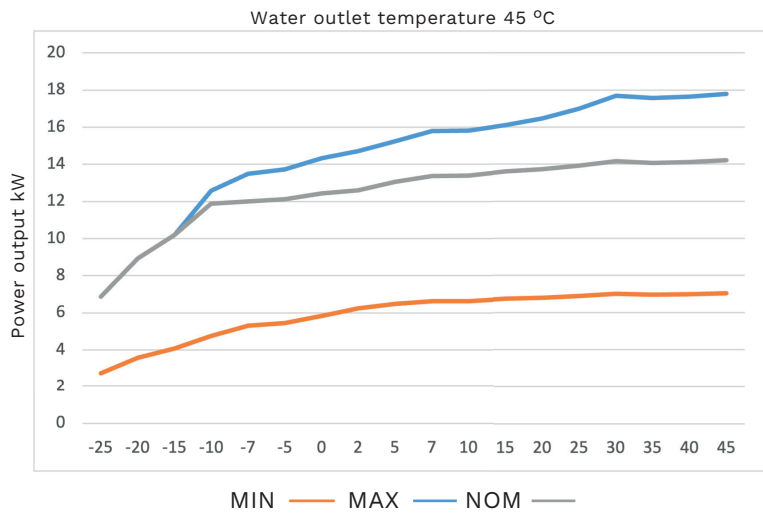

Ambient temperature	Power output (kW)		
	MAX	MIN	NOM
-25	5,91	2,36	5,91
-20	7,65	3,06	7,65
-15	9,19	3,68	9,19
-10	10,98	4,2	10,5
-7	12,41	4,89	11,03
-5	12,53	4,98	11,06
0	12,85	5,23	11,14
2	13,45	5,71	11,53
5	13,76	5,84	11,79
7	14,13	5,92	11,96
10	14,43	6,04	12,21
15	14,6	6,11	12,35
20	14,99	6,18	12,49
25	15,45	6,26	12,64
30	16,1	6,38	12,88
35	16,19	6,41	12,95
40	16,35	6,47	13,08
45	16,76	6,64	13,41

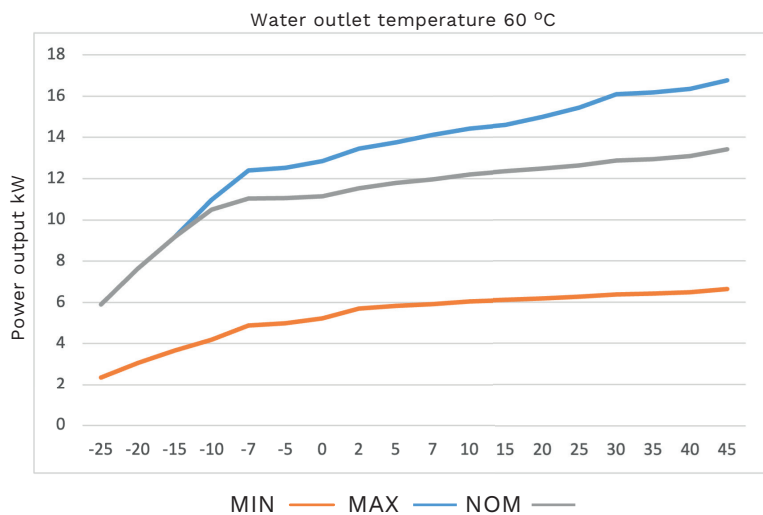

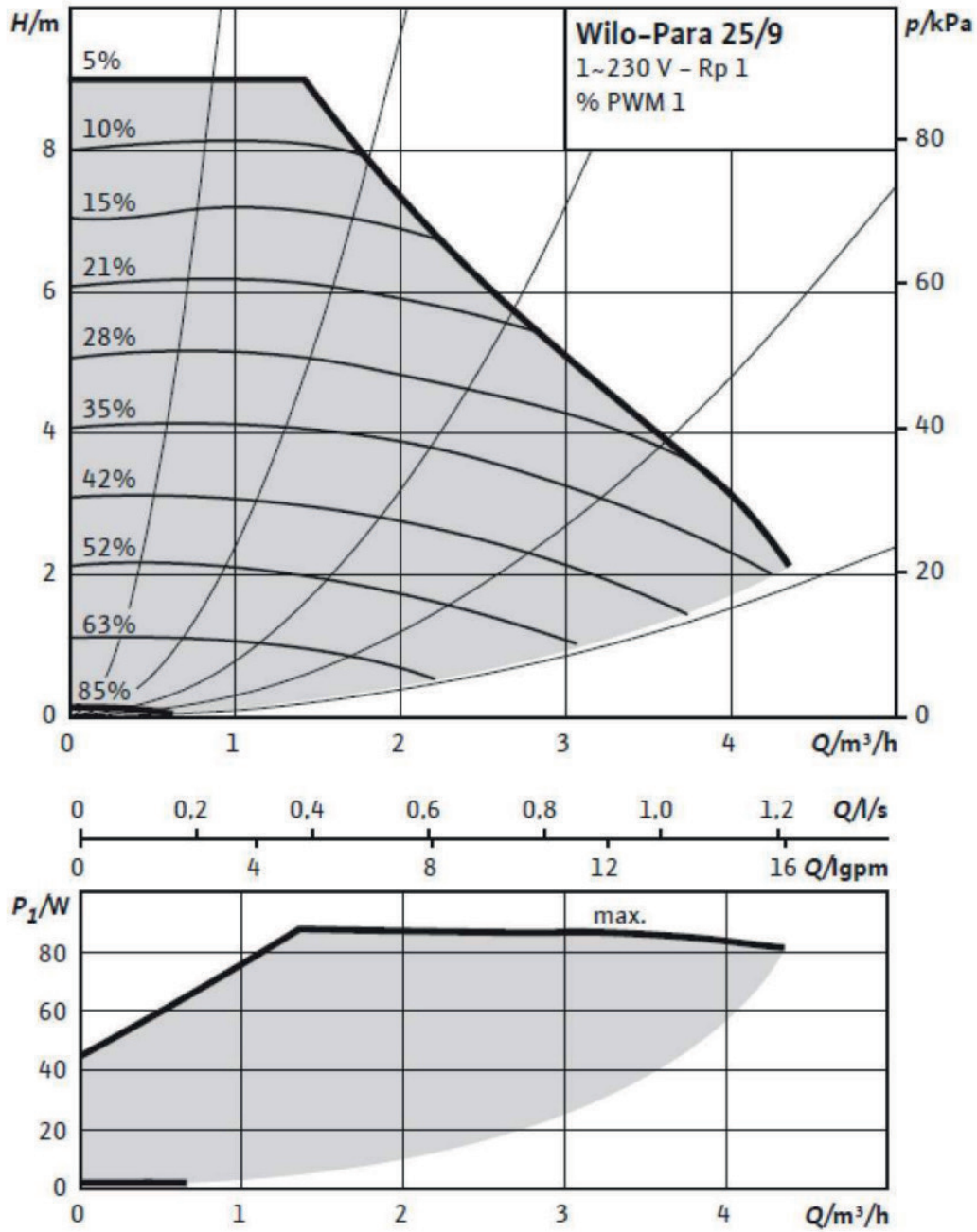

		ERA^{pro} 6 kW	ERA^{pro} 9 kW	ERA^{pro} 13 kW	ERA^{pro} 16 kW
Related Water Flow Rate	m³/h	1,03	1,55	2,20	2,75
Water Pressure Drop	kPa	15	20	22	35

	ERA ^{pro} 6 kW	ERA ^{pro} 9 kW	ERA ^{pro} 13 kW	ERA ^{pro} 16 kW
A7/35	4,171 / 0,825 / 5,06	5,867 / 1,207 / 4,86	7,907 / 1,573 / 5,03	10,082 / 2,37 / 4,949
A7/55	4,092 / 1,274 / 3,20	5,949 / 1,872 / 3,18	7,858 / 2,56 / 3,07	9,922 / 3,124 / 3,176
Lwa	47	53	54	54
Q = 2	r = 1m	39	45	46
	r = 3m	29	35	36
	r = 5m	25	31	32
Q = 1	r = 1m	36	42	43
	r = 3m	26	32	33
	r = 5m	22	28	29
Q = 4	r = 1m	42	48	49
	r = 3m	32	38	39
	r = 5m	28	34	35

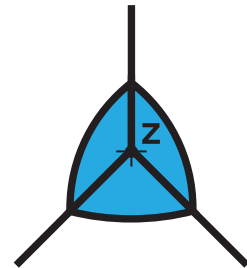
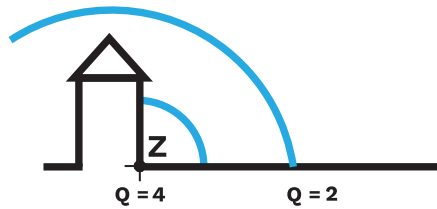
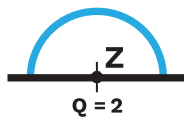
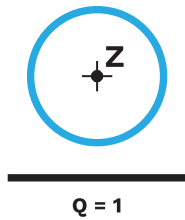

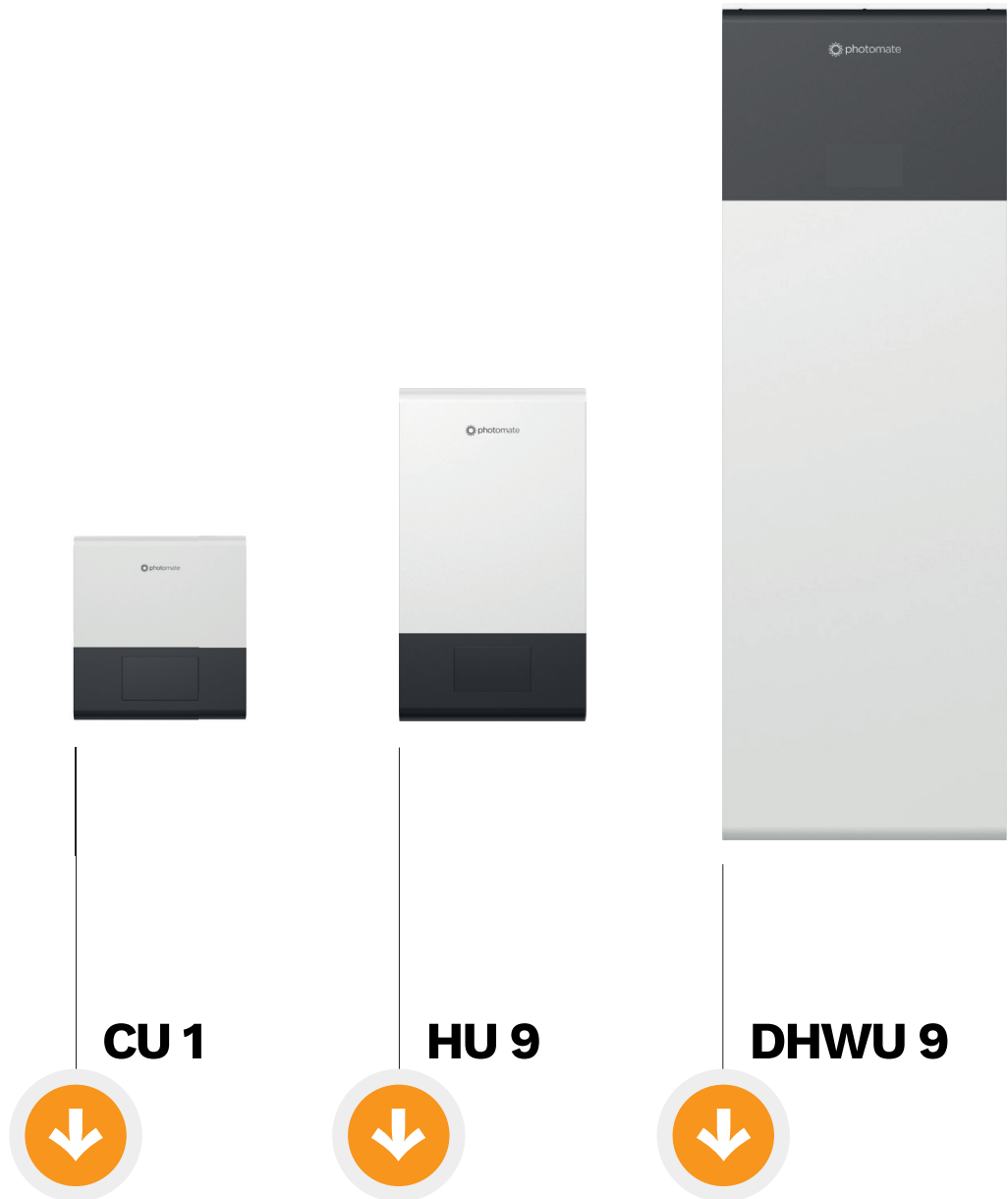

Water heating control	YES	YES	YES
Heating	2 circuits	2 circuits	2 circuits
Cooling	1 circuit	1 circuit	1 circuit
Auxiliary source control	YES	YES	YES
Integrated auxiliary power supply	NO	YES / 9kW	YES / 9kW
Power supply	1x 230 V	3x 400 V	3x 400 V
Circuit breaker	1 x 10 A/B	3 x 16 A/B	3 x 16 A/B
Connection dimensions	-	1"	1"
Dimensions (W x H x D)	390mm x 420mm x 100mm	418mm x 750mm x 310mm	640mm x 1950mm x 750mm
Weight	7,5kg	35kg	125kg
Hot water tank	-	-	200l - stainless steel



CU 1

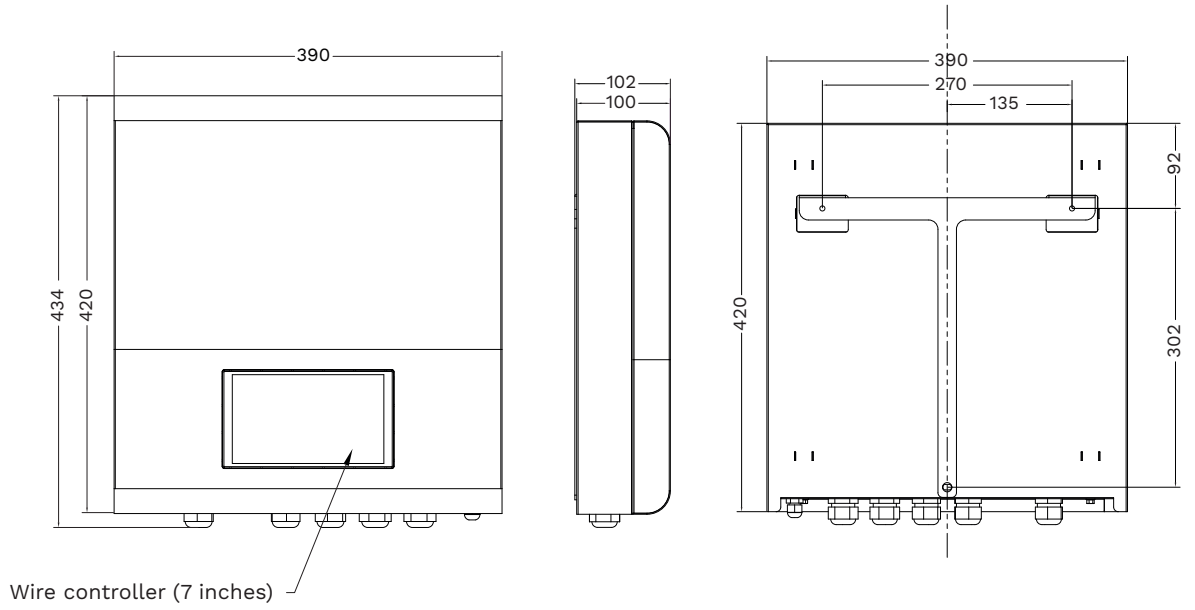

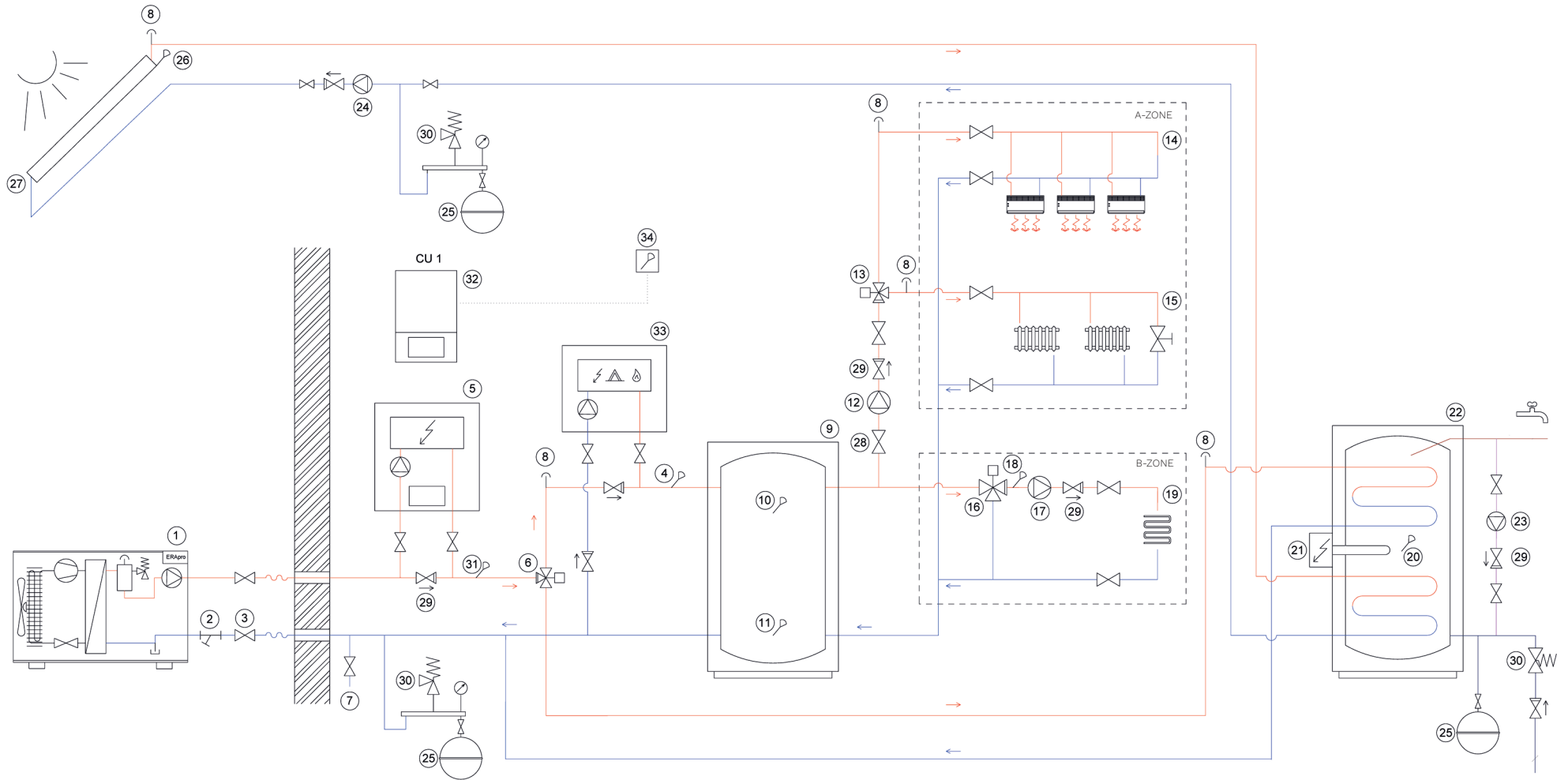

LINE LEGEND:

- SUPPLY OF HEATING/COOLING WATER
- RETURN OF HEATING/COOLING WATER
- DHW - HOT WATER
- DHW - COLD WATER
- DHW - CIRCULATION

No.	DESCRIPTION	No.	DESCRIPTION	No.	DESCRIPTION	No.	DESCRIPTION
1	Outdoor unit	10	Upper buffer tank temperature sensor	19	Underfloor heating	28	Shut-off valve
2	Filter	11	Lower buffer tank temperature sensor	20	DHW temperature sensor	29	Non-return valve
3	Shut-off valve	12	External circulation pump	21	DHW electric heater	30	Safety valve
4	System outlet temperature sensor	13	3-way valve, heating / cooling	22	DHW storage tank	31	Outlet water temperature sensor
5	Auxiliary heat source	14	Fan coils	23	DHW circulation pump	32	Control module CU1
6	3-way valve, DHW / heating	15	Radiators	24	Solar circulation pump	33	External heat source
7	Drain valve	16	3-way valve, mixing circuit	25	Expansion vessel	34	External room temperature sensor
8	Air vent valve	17	Mixing circuit pump	26	Solar collector temperature sensor		
9	Buffer tank	18	Mixing circuit outlet temperature sensor	27	Solar collector		

CU1 - Electrical connection

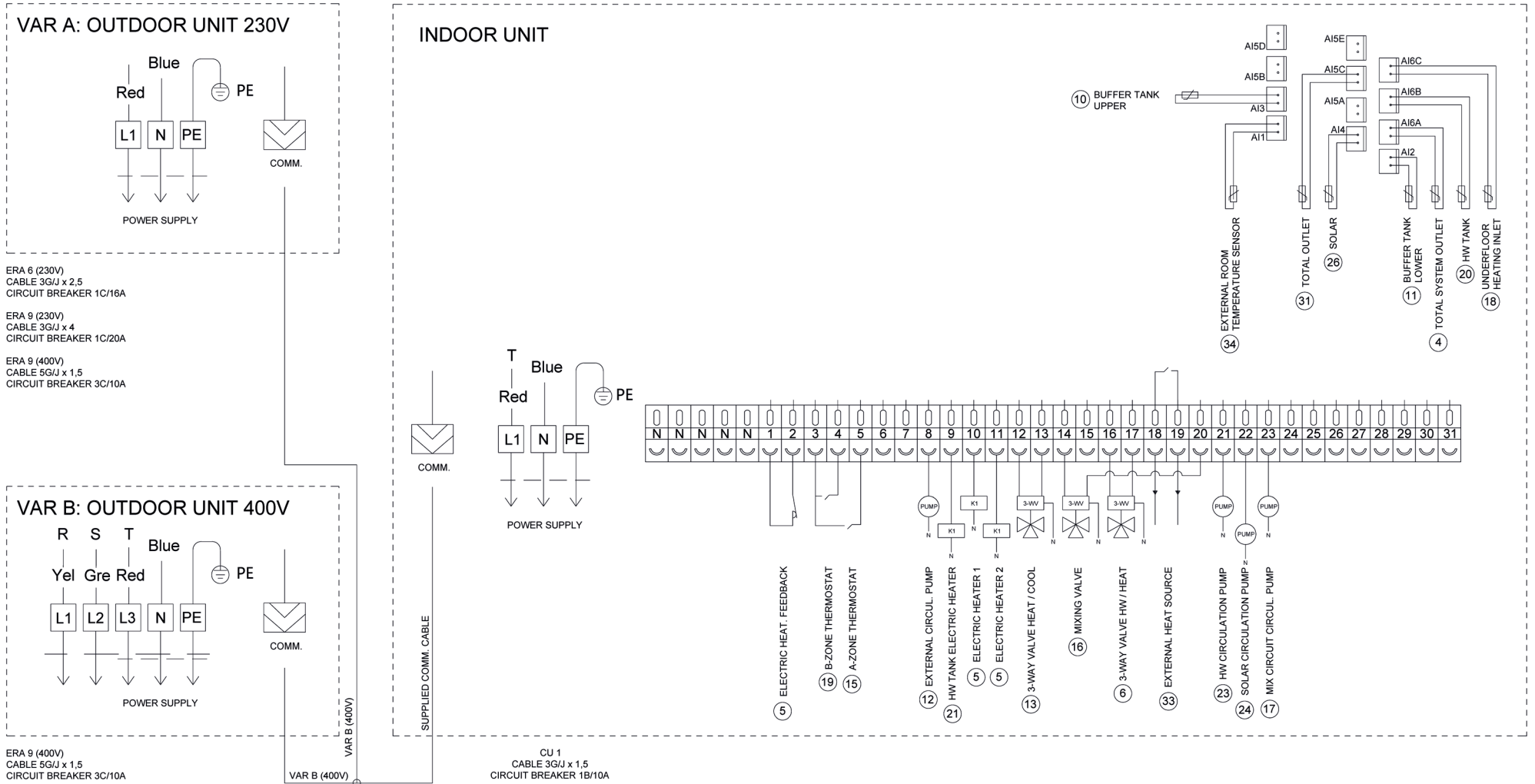

LINE LEGEND

- NEEDS TO BE CONNECTED
- CONNECTED FROM FACTORY



HU 9

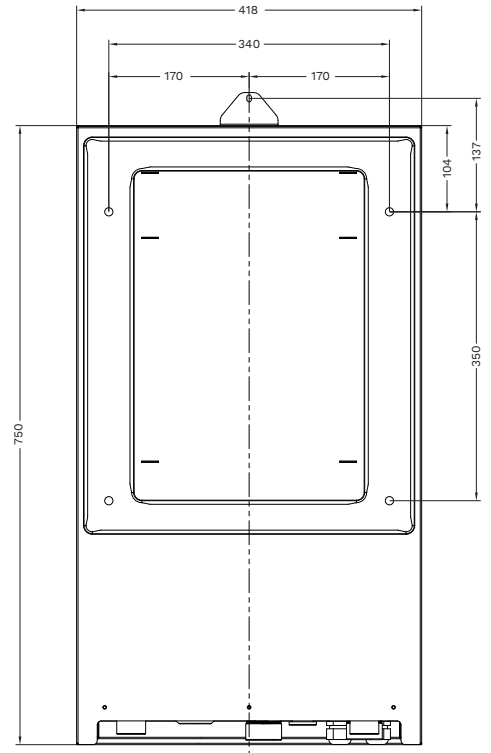
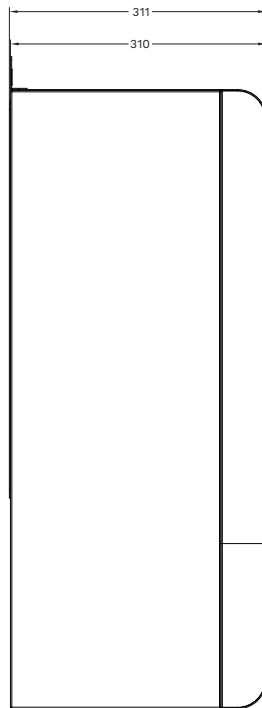
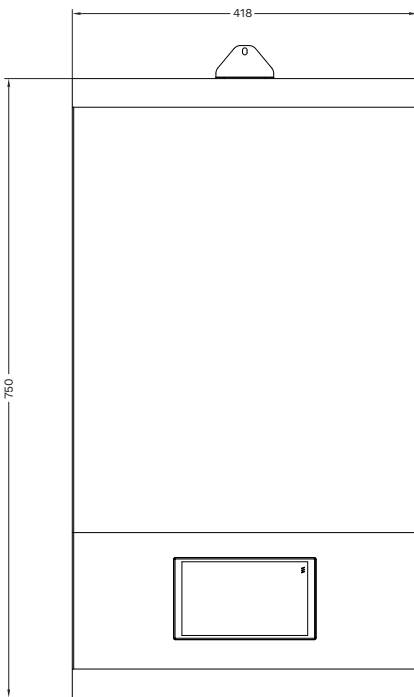
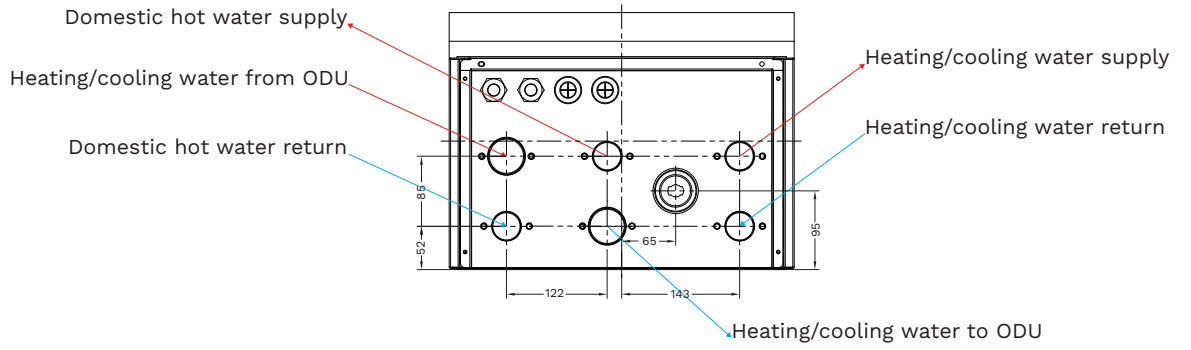

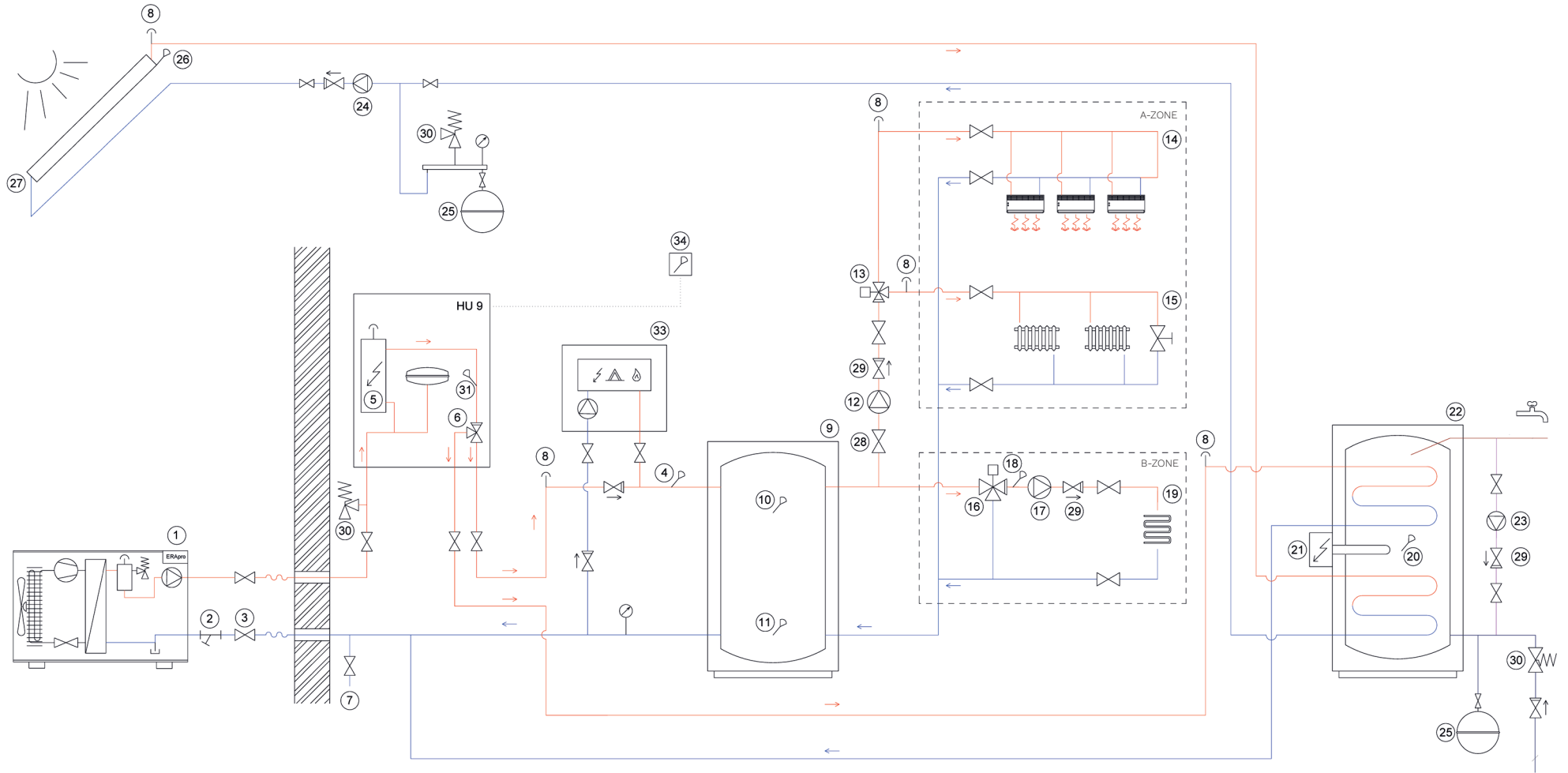

LINE LEGEND:

- SUPPLY OF HEATING/COOLING WATER
- RETURN OF HEATING/COOLING WATER
- DHW - HOT WATER
- DHW - COLD WATER
- DHW - CIRCULATION

No.	DESCRIPTION	No.	DESCRIPTION	No.	DESCRIPTION	No.	DESCRIPTION
1	Outdoor unit	10	Upper buffer tank temperature sensor	19	Underfloor heating	28	Shut-off valve
2	Filter	11	Lower buffer tank temperature sensor	20	DHW temperature sensor	29	Non-return valve
3	Shut-off valve	12	External circulation pump	21	DHW electric heater	30	Safety valve
4	System outlet temperature sensor	13	3-way valve, heating / cooling	22	DHW storage tank	31	Outlet water temperature sensor
5	Auxiliary heat source	14	Fan coils	23	DHW circulation pump	33	External heat source
6	3-way valve, DHW / heating	15	Radiators	24	Solar circulation pump	34	External room temperature sensor
7	Drain valve	16	3-way valve, mixing circuit	25	Expansion vessel		
8	Air vent valve	17	Mixing circuit pump	26	Solar collector temperature sensor		
9	Buffer tank	18	Mixing circuit outlet temperature sensor	27	Solar collector		

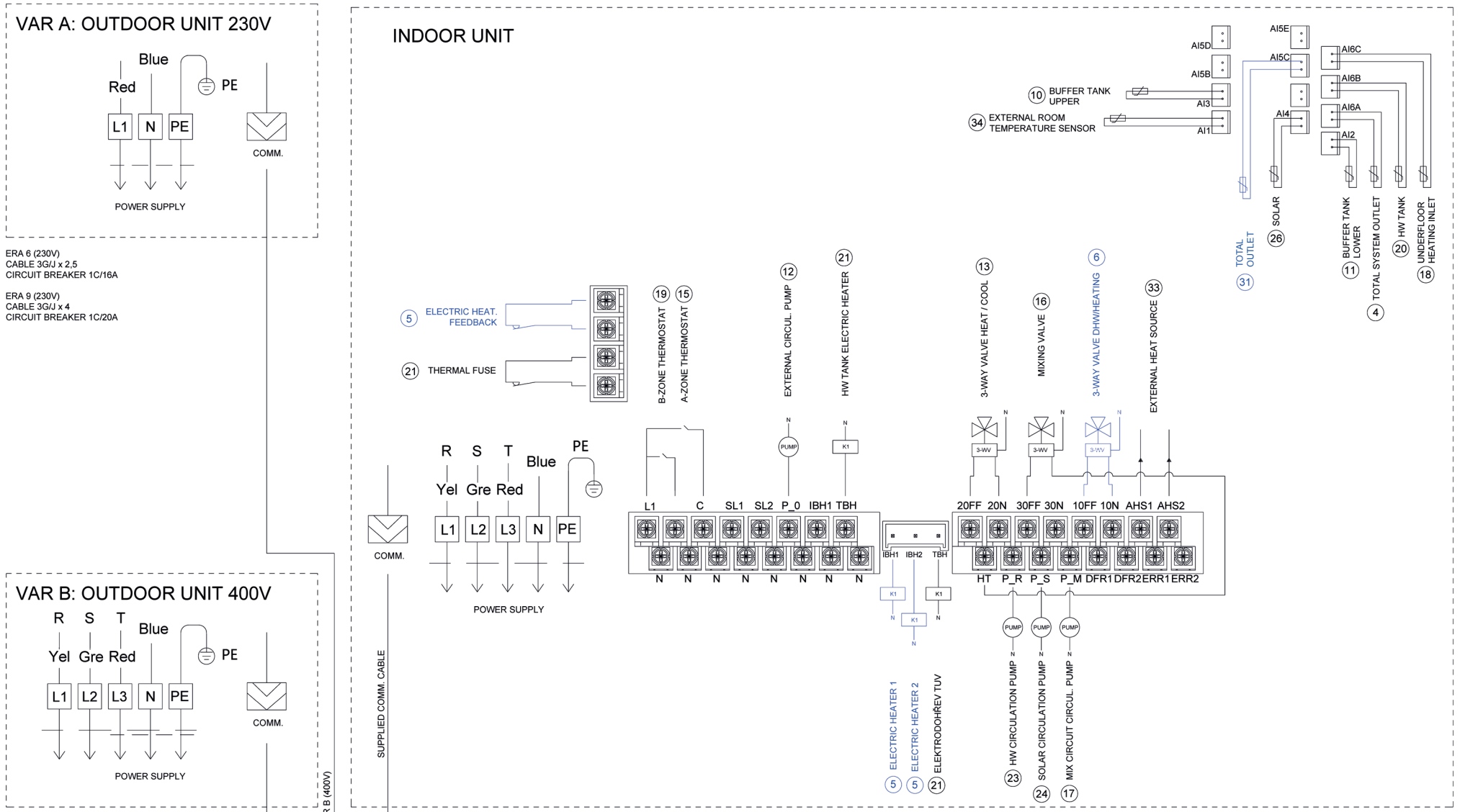

ERA 6 (230V)
CABLE 3G/J x 2.5
CIRCUIT BREAKER 1C/16A

ERA 9 (230V)
CABLE 3G/J x 4
CIRCUIT BREAKER 1C/20A

ERA 9 (400V)
CABLE 5G/J x 1.5
CIRCUIT BREAKER 3C/10A

ERA 13 (400V)
CABLE 5G/J x 1.5
CIRCUIT BREAKER 3C/10A

ERA 16 (400V)
CABLE 5G/J x 1.5
CIRCUIT BREAKER 3C/13A

HU 9
CABLE 5G/J x 2.5
CIRCUIT BREAKER 3B/16A

LINE LEGEND

— NEEDS TO BE CONNECTED

— CONNECTED FROM FACTORY

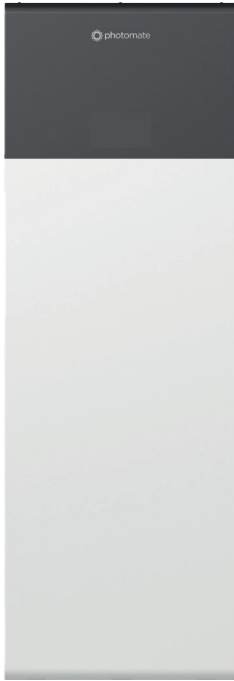

DHWU 9

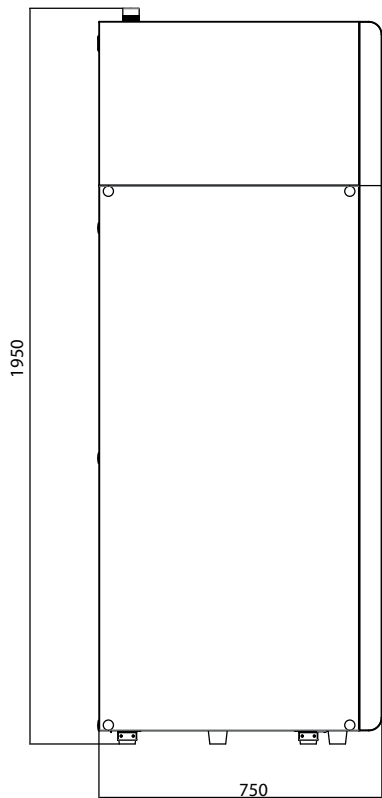
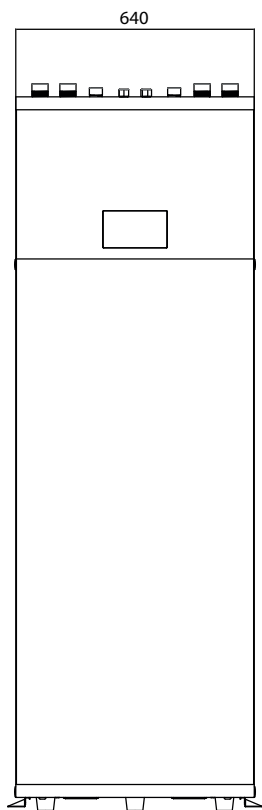
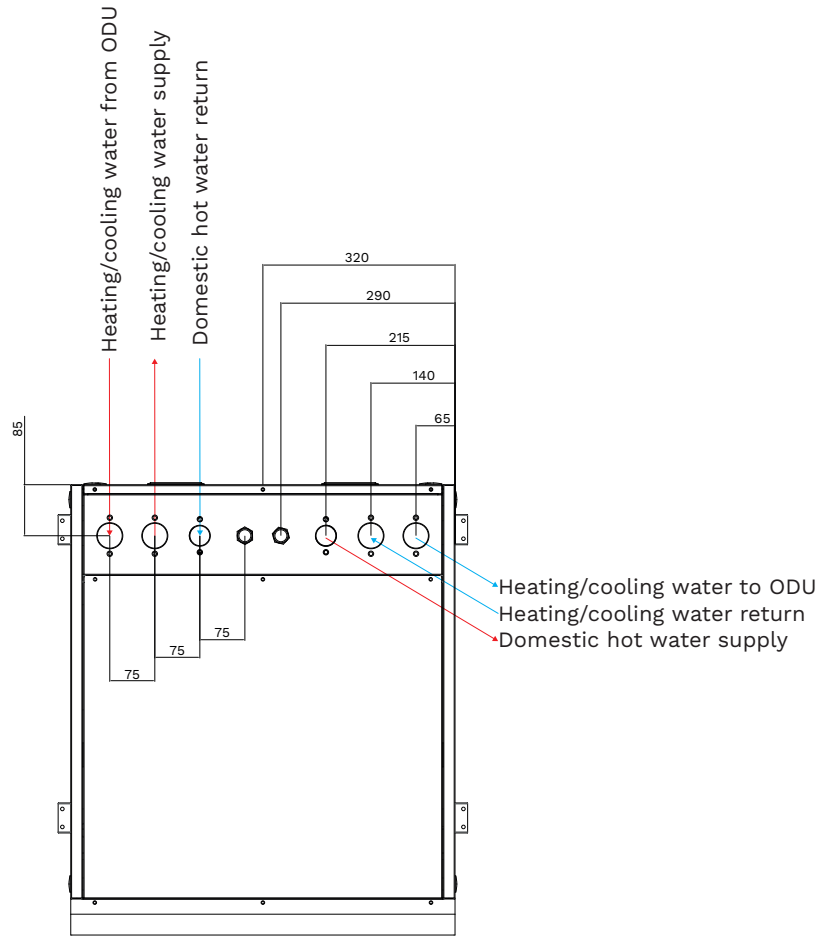

DHWU9 - Hydraulic connection

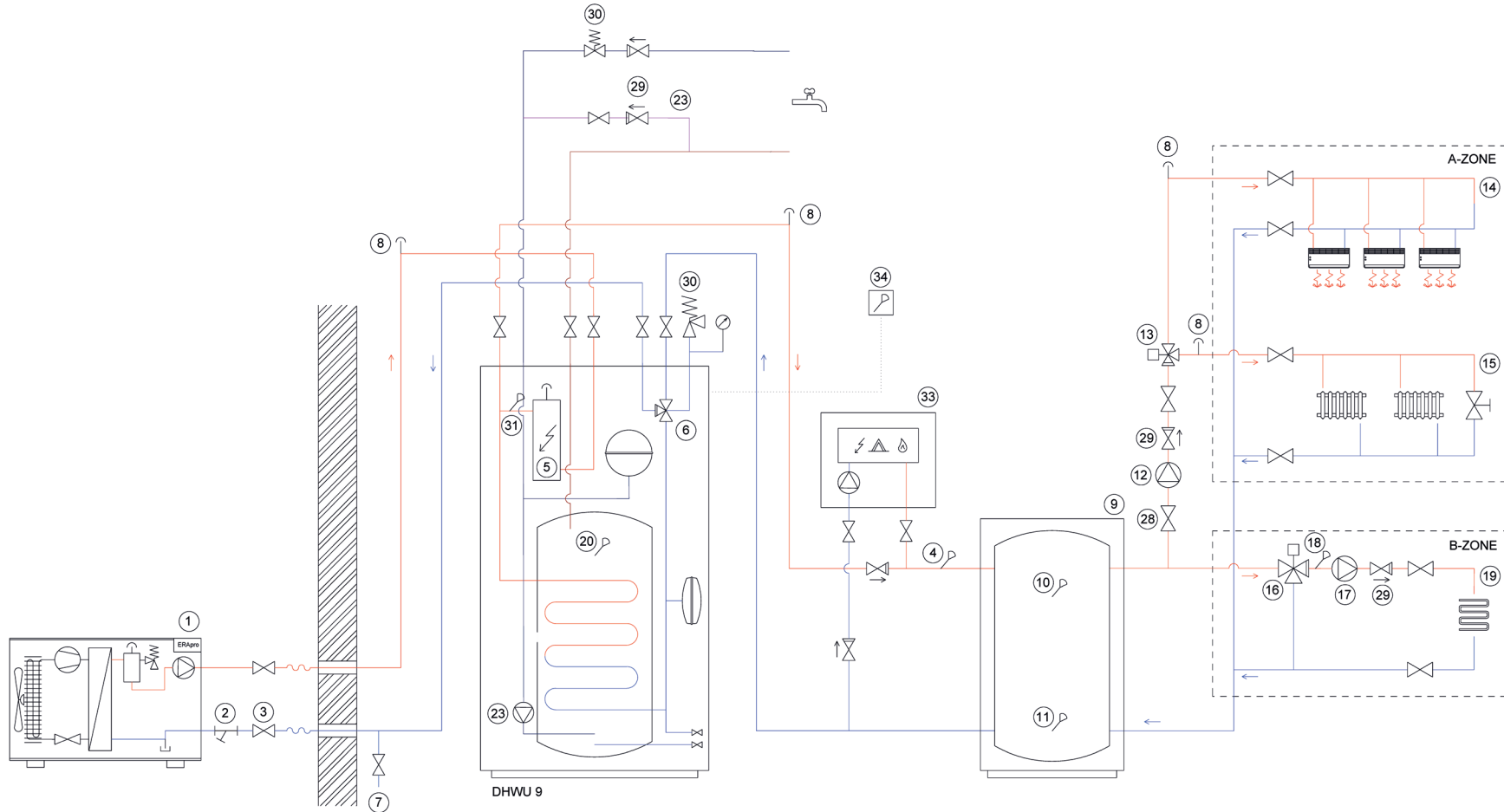

LINE LEGEND:

- SUPPLY OF HEATING/COOLING WATER
- RETURN OF HEATING/COOLING WATER
- DHW - HOT WATER
- DHW - COLD WATER
- DHW - CIRCULATION

No.	DESCRIPTION	No.	DESCRIPTION	No.	DESCRIPTION
1	Outdoor unit	10	Buffer Tank Lower Sensor	19	Underfloor heating
2	Filter	11	External Circulation Pump	20	DHW temperature sensor
3	Shut-off valve	12	3-Way Valve, Heat / Cool	23	DHW circulation pump
4	System outlet temperature sensor	13	Fancoils	28	Shut-off valve
5	Auxiliary heat source	14	Radiators	29	Non-return valve
6	3-way valve, DHW / heating	15	3-Way Valve, Mixing	30	Safety valve
7	Drain valve	16	3-Way Valve, Hot Water / Heat	31	Outlet water temperature sensor
8	Air vent valve	17	Mixing Circuit Circulation Pump	33	External heat source
9	Buffer tank	18	Underfloor Heating Inlet Water Sensor	34	External room temperature sensor

DHWU - Electrical connection

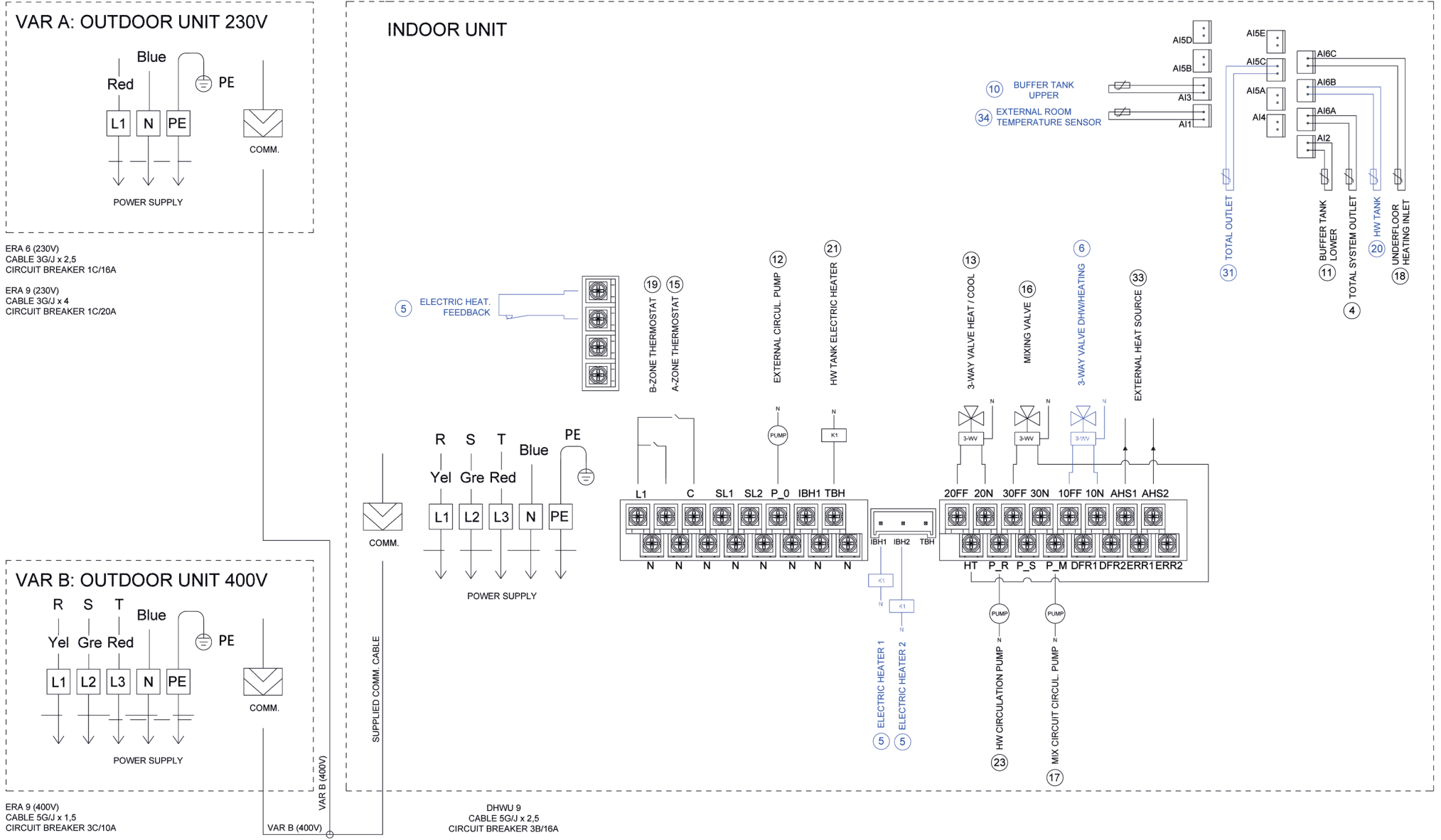

LINE LEGEND
 ———— NEEDS TO BE CONNECTED
 ———— CONNECTED FROM FACTORY

ERA 6 (230V)
CABLE 3G/J x 2,5
CIRCUIT BREAKER 1C/16A

ERA 9 (230V)
CABLE 3G/J x 4
CIRCUIT BREAKER 1C/20A

ERA 9 (400V)
CABLE 5G/J x 1,5
CIRCUIT BREAKER 3C/10A

ERA 13 (400V)
CABLE 5G/J x 1,5
CIRCUIT BREAKER 3C/10A

ERA 16 (400V)
CABLE 5G/J x 1,5
CIRCUIT BREAKER 3C/13A

1. General requirements

The correct quality of heating water is essential for the safe, efficient, and long-term operation of ERA^{pro} heat pumps. Unsuitable water quality can lead to corrosion, sediment formation, clogging of heat exchangers, reduced efficiency of the equipment, and a shortened service life.

The heating system must be designed as a closed system and must be designed, installed, and operated in accordance with:

- VDI Guideline 2035 (Sheets 1 and 2)
- EN 14868 standard (water treatment in heating systems)
- EN 1717 standard (drinking water protection)
- and applicable national technical and hygiene regulations

2. Requirements for heating water quality

The heating water used to fill and top up the heating system must meet the following parameters:

Parameter	Recommended values
pH – general	7.5 – 9.5
pH – systems containing steel (e.g., storage tanks or water heaters)	8.2 – 9.0
Electrical conductivity	max. ≤ 600 μS/cm, preferably ≤ 100 μS/cm
Total hardness	filling max. 80 mg/l CaCO ₃ water in the system max: 300 mg/l CaCO ₃
Chlorides (Cl⁻)	max. ≤ 250 mg/l, preferably as low as possible
Sulfates + nitrates	max. ≤ 50 mg/l, preferably as low as possible
Total iron (Fe)	filling max. 0.2 mg/l water in the system max: 0.8 mg/l
Turbidity	max. ≤ 5 NTU (clear water without turbidity)
Dissolved oxygen	max. ≤ 0.1 mg/l

These values represent compromise, technically correct limits that respect the principles of VDI 2035 while taking into account the operational reality of installations.

3. Demineralization of heating water

Demineralization of heating water is:

- mandatory if the inlet or make-up water does not meet the above limits
- Highly recommended for new installations, larger system volumes, or when water is added into the heating circuit repeatedly and frequently

The manufacturer of ERA^{pro} considers demineralization to be the most effective way to prevent corrosion and limescale formation without the need for chemical additives.

4. Filling and refilling the system

- Filling and replenishing heating water must be carried out in accordance with EN 1717, and protection of drinking water against backflow must be ensured
- Water replenishment must be minimized and recorded
- Each water refill must meet the same quality requirements as the initial filling

5. Water quality control

To ensure proper functioning, efficient operation, and long service life of the heat pump and the entire heating system, we recommend checking the quality of the heating water.

Recommended inspection procedure

- When commissioning the equipment
- After 8–12 weeks of operation, we recommend repeating the measurements to confirm that the chemical properties of the water have stabilized.